

10-bit high-speed low-power ADC**TDA8763A****FEATURES**

- 10-bit resolution
- Sampling rate up to 50 MHz
- DC sampling allowed
- One clock cycle conversion only
- High signal-to-noise ratio over a large analog input frequency range (9.4 effective bits at 4.43 MHz full-scale input at $f_{clk} = 40$ MHz)
- No missing codes guaranteed
- In range (IR) CMOS output
- TTL compatible digital inputs
- 3 to 5 V CMOS digital outputs
- Low-level AC clock input signal allowed
- External reference voltage regulator
- Power dissipation only 180 mW (typical)
- Low analog input capacitance, no buffer amplifier required
- No sample-and-hold circuit required.

APPLICATIONS

High-speed analog-to-digital conversion for:

- Video data digitizing
- Radar pulse analysis
- Transient signal analysis
- High energy physics research
- $\Sigma\Delta$ modulators
- Medical imaging.

GENERAL DESCRIPTION

The TDA8763A is a 10-bit high-speed low-power analog-to-digital converter (ADC) for professional video and other applications. It converts the analog input signal into 10-bit binary-coded digital words at a maximum sampling rate of 50 MHz. All digital inputs and outputs are TTL compatible, although a low-level sine-wave clock input signal is allowed.

The device requires an external source to drive its reference ladder. If the application requires that the reference is driven via internal sources the recommendation is to use the TDA8763.

ORDERING INFORMATION

TYPE NUMBER	PACKAGE			SAMPLING FREQUENCY (MHz)
	NAME	DESCRIPTION	VERSION	
TDA8763AM/3	SSOP28	plastic shrink small outline package; 28 leads; body width 5.3 mm	SOT341-1	30
TDA8763AM/4	SSOP28		SOT341-1	40
TDA8763AM/5	SSOP28		SOT341-1	50

10-bit high-speed low-power ADC

TDA8763A

QUICK REFERENCE DATA

SYMBOL	PARAMETER	CONDITIONS	MIN.	TYP.	MAX.	UNIT
V _{CCA}	analog supply voltage		4.75	5.0	5.25	V
V _{CCD}	digital supply voltage		4.75	5.0	5.25	V
V _{CCO}	output stages supply voltage		3.0	3.3	5.25	V
I _{CCA}	analog supply current		–	18	24	mA
I _{CCD}	digital supply current		–	16	21	mA
I _{CCO}	output stages supply current	f _{clk} = 40 MHz; ramp input	–	2	4	mA
INL	integral non-linearity	f _{clk} = 40 MHz; ramp input	–	±0.8	±2.0	LSB
DNL	differential non-linearity	f _{clk} = 40 MHz; ramp input	–	±0.5	±0.9	LSB
f _{clk(max)}	maximum clock frequency					
	TDA8763AM/3		30	–	–	MHz
	TDA8763AM/4		40	–	–	MHz
	TDA8763AM/5		50	–	–	MHz
P _{tot}	total power dissipation	f _{clk} = 40 MHz; ramp input	–	180	258	mW

10-bit high-speed low-power ADC

TDA8763A

BLOCK DIAGRAM

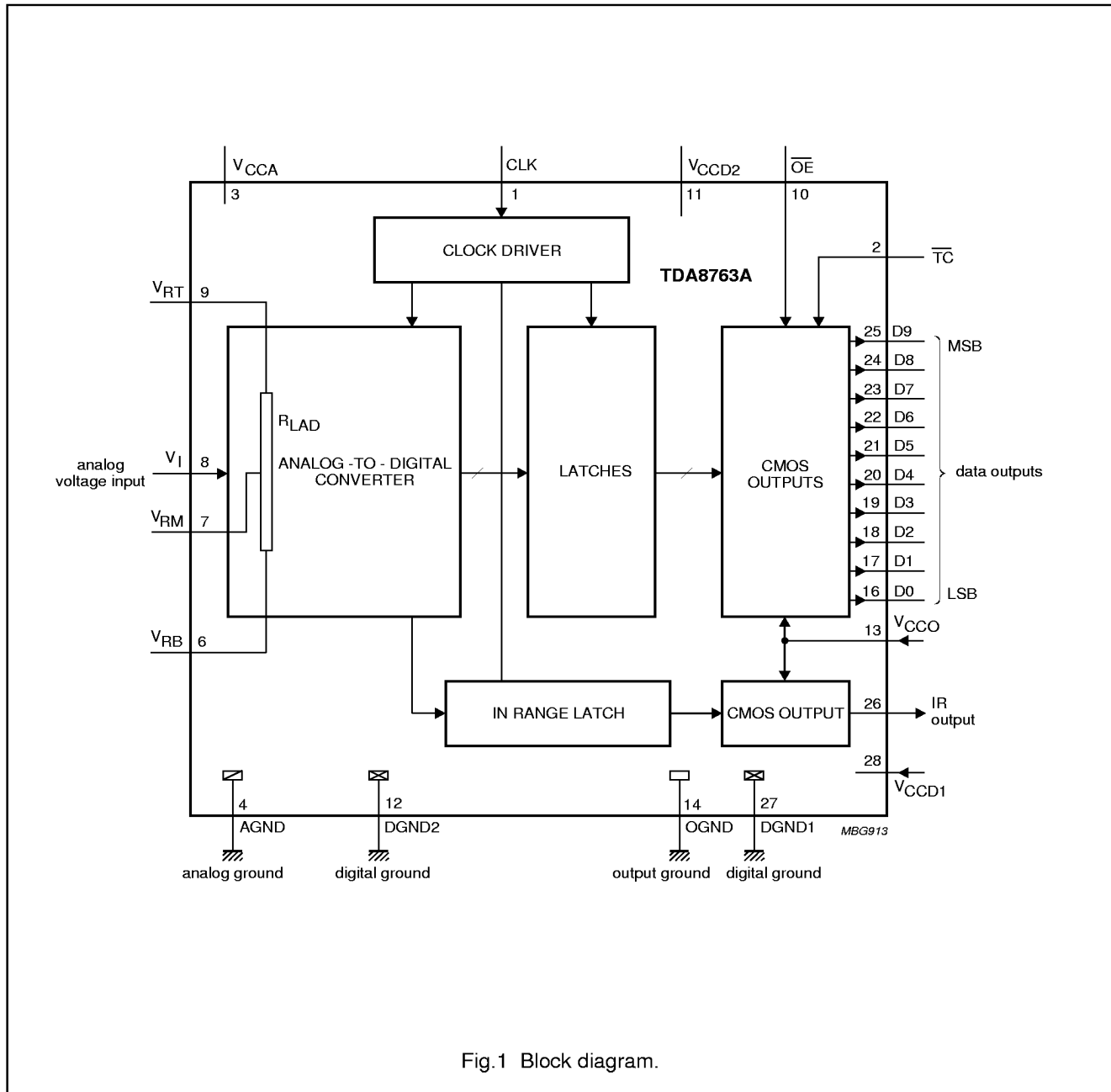

Fig.1 Block diagram.

10-bit high-speed low-power ADC

TDA8763A

PINNING

SYMBOL	PIN	DESCRIPTION
CLK	1	clock input
\overline{TC}	2	two's complement input (active LOW)
V_{CCA}	3	analog supply voltage (+5 V)
AGND	4	analog ground
n.c.	5	not connected
V_{RB}	6	reference voltage BOTTOM input
V_{RM}	7	reference voltage MIDDLE input
V_I	8	analog input voltage
V_{RT}	9	reference voltage TOP input
\overline{OE}	10	output enable input (CMOS level input, active LOW)
V_{CCD2}	11	digital supply voltage 2 (+5 V)
DGND2	12	digital ground 2
V_{CCO}	13	supply voltage for output stages (+3 to +5 V)
OGND	14	output ground
n.c.	15	not connected
D0	16	data output; bit 0 (LSB)
D1	17	data output; bit 1
D2	18	data output; bit 2
D3	19	data output; bit 3
D4	20	data output; bit 4
D5	21	data output; bit 5
D6	22	data output; bit 6
D7	23	data output; bit 7
D8	24	data output; bit 8
D9	25	data output; bit 9 (MSB)
IR	26	in range data output
DGND1	27	digital ground 1
V_{CCD1}	28	digital supply voltage 1 (+5 V)

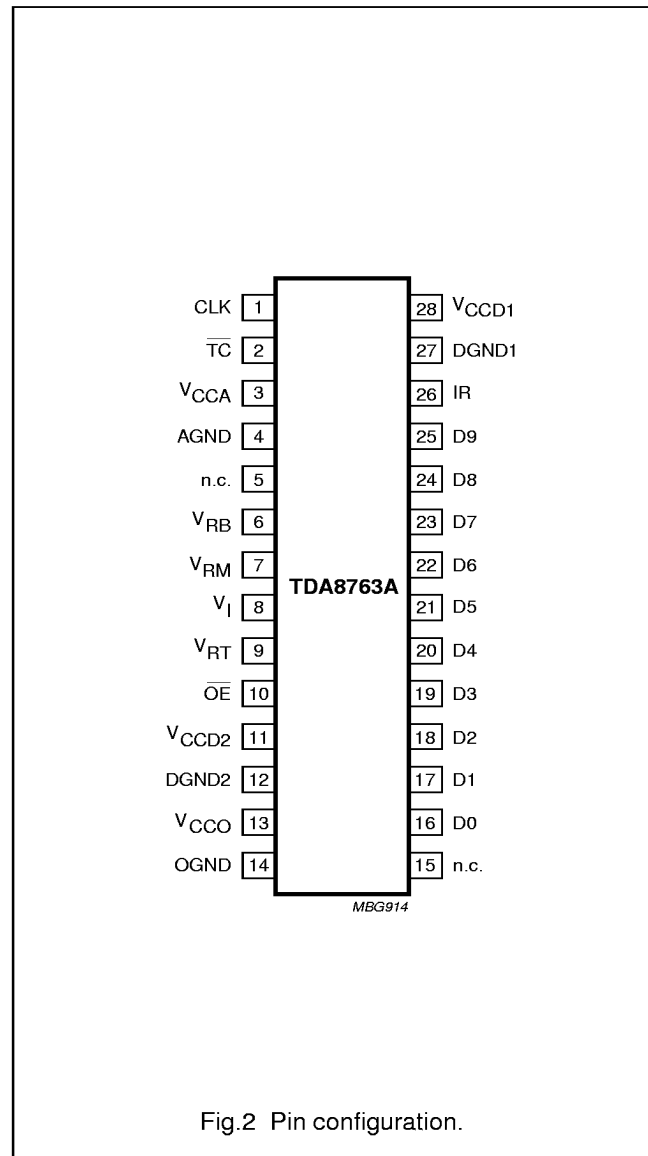

Fig.2 Pin configuration.

10-bit high-speed low-power ADC

TDA8763A

LIMITING VALUES

In accordance with the Absolute Maximum Rating System (IEC 134).

SYMBOL	PARAMETER	CONDITIONS	MIN.	MAX.	UNIT
V_{CCA}	analog supply voltage	note 1	-0.3	+7.0	V
V_{CCD}	digital supply voltage	note 1	-0.3	+7.0	V
V_{CCO}	output stages supply voltage	note 1	-0.3	+7.0	V
ΔV_{CC}	supply voltage difference				
	$V_{CCA} - V_{CCD}$		-1.0	+1.0	V
	$V_{CCA} - V_{CCO}$		-1.0	+4.0	V
	$V_{CCD} - V_{CCO}$		-1.0	+4.0	V
V_I	input voltage	referenced to AGND	-0.3	+7.0	V
$V_{clk(p-p)}$	AC input voltage for switching (peak-to-peak value)	referenced to DGND	-	V_{CCD}	V
I_O	output current		-	10	mA
T_{stg}	storage temperature		-55	+150	°C
T_{amb}	operating ambient temperature		-40	+85	°C
T_j	junction temperature		-	+150	°C

Note

1. The supply voltages V_{CCA} , V_{CCD} and V_{CCO} may have any value between -0.3 V and +7.0 V provided that the supply voltage differences ΔV_{CC} are respected.

HANDLING

Inputs and outputs are protected against electrostatic discharges in normal handling. However, to be totally safe, it is desirable to take normal precautions appropriate to handling integrated circuits.

THERMAL CHARACTERISTICS

SYMBOL	PARAMETER	CONDITIONS	VALUE	UNIT
$R_{th\ j-a}$	thermal resistance from junction to ambient	in free air	110	K/W

10-bit high-speed low-power ADC

TDA8763A

CHARACTERISTICS

$V_{CCA} = V_3$ to $V_4 = 4.75$ to 5.25 V; $V_{CCD} = V_{11}$ to V_{12} and V_{28} to $V_{27} = 4.75$ to 5.25 V; $V_{CCO} = V_{13}$ to $V_{14} = 3.0$ to 5.25 V; AGND and DGND shorted together; $T_{amb} = 0$ to $+70$ °C; typical values measured at $V_{CCA} = V_{CCD} = 5$ V and $V_{CCO} = 3.3$ V; $V_{i(p-p)} = 2.0$ V; $C_L = 15$ pF and $T_{amb} = 25$ °C; unless otherwise specified.

SYMBOL	PARAMETER	CONDITIONS	MIN.	TYP.	MAX.	UNIT
Supply						
V_{CCA}	analog supply voltage		4.75	5.0	5.25	V
V_{CCD1}	digital supply voltage 1		4.75	5.0	5.25	V
V_{CCD2}	digital supply voltage 2		4.75	5.0	5.25	V
V_{CCO}	output stages supply voltage		3.0	3.3	5.25	V
ΔV_{CC}	supply voltage difference					
	$V_{CCA} - V_{CCD}$		-0.20	-	+0.20	V
	$V_{CCA} - V_{CCO}$		-0.20	-	+2.25	V
	$V_{CCD} - V_{CCO}$		-0.20	-	+2.25	V
I_{CCA}	analog supply current		-	18	24	mA
I_{CCD}	digital supply current		-	16	21	mA
I_{CCO}	output stages supply current	$f_{clk} = 40$ MHz; ramp input	-	2	4	mA
Inputs						
CLOCK INPUT CLK (REFERENCED TO DGND); note 1						
V_{IL}	LOW level input voltage		0	-	0.8	V
V_{IH}	HIGH level input voltage		2.0	-	V_{CCD}	V
I_{iL}	LOW level input current	$V_{clk} = 0.8$ V	-1	0	+1	μ A
I_{iH}	HIGH level input current	$V_{clk} = 2.0$ V	-	2	10	μ A
Z_i	input impedance	$f_{clk} = 40$ MHz	-	2	-	k Ω
C_i	input capacitance	$f_{clk} = 40$ MHz	-	2	-	pF
INPUTS \overline{OE} AND \overline{TC} (REFERENCED TO DGND); see Table 2						
V_{IL}	LOW level input voltage		0	-	0.8	V
V_{IH}	HIGH level input voltage		2.0	-	V_{CCD}	V
I_{iL}	LOW level input current	$V_{iL} = 0.8$ V	-1	-	-	μ A
I_{iH}	HIGH level input current	$V_{iH} = 2.0$ V	-	-	1	μ A
V_i (ANALOG INPUT VOLTAGE REFERENCED TO AGND)						
I_{iL}	LOW level input current	$V_i = V_{RB} = 1.3$ V	-	17	-	μ A
I_{iH}	HIGH level input current	$V_i = V_{RT} = 3.67$ V	-	35	-	μ A
Z_i	input impedance	$f_i = 4.43$ MHz	-	8	-	k Ω
C_i	input capacitance	$f_i = 4.43$ MHz	-	5	-	pF

10-bit high-speed low-power ADC

TDA8763A

SYMBOL	PARAMETER	CONDITIONS	MIN.	TYP.	MAX.	UNIT
Reference voltages for the resistor ladder using the internal voltage regulator; see Table 1						
V_{RB}	reference voltage BOTTOM		1.2	1.3	2.45	V
V_{RT}	reference voltage TOP		3.0	3.67	$V_{CCA} - 0.8$	V
V_{diff}	differential reference voltage $V_{RT} - V_{RB}$		1.8	2.37	3.0	V
I_{ref}	reference current	$V_{RT} - V_{RB} = 2.37$ V	–	9.7	–	mA
R_{LAD}	resistor ladder		–	245	–	Ω
TC_{RLAD}	temperature coefficient of the resistor ladder		–	1860	–	ppm
			–	456	–	m Ω /K
V_{osB}	offset voltage BOTTOM	note 2	–	175	–	mV
V_{osT}	offset voltage TOP	note 2	–	175	–	mV
$V_{i(p-p)}$	analog input voltage (peak-to-peak value)	note 3	1.5	2.02	2.5	V
Outputs						
DIGITAL OUTPUTS D9 TO D0 AND IR (REFERENCED TO OGND)						
V_{OL}	LOW level output voltage	$I_{OL} = 1$ mA	0	–	0.5	V
V_{OH}	HIGH level output voltage	$I_{OH} = -1$ mA	$V_{CCO} - 0.5$	–	V_{CCO}	V
I_{OZ}	output current in 3-state mode	0.5 V < V_O < V_{CCO}	–20	–	+20	μ A
Switching characteristics						
CLOCK INPUT CLK; see Fig.4; note 1						
$f_{clk(max)}$	maximum clock frequency					
	TDA8763AM/3		30	–	–	MHz
	TDA8763AM/4		40	–	–	MHz
	TDA8763AM/5		50	–	–	MHz
t_{CPH}	clock pulse width HIGH		7.5	–	–	ns
t_{CPL}	clock pulse width LOW		5.5	–	–	ns
Analog signal processing						
LINEARITY						
INL	integral non-linearity	$f_{clk} = 40$ MHz; ramp input	–	± 0.8	± 2.0	LSB
DNL	differential non-linearity	$f_{clk} = 40$ MHz; ramp input	–	± 0.5	± 0.9	LSB
OFER	offset error	middle code; $V_{RB} = 1.3$ V; $V_{RT} = 3.67$ V	–	± 1	–	LSB
GER	gain error (from device to device) using external reference voltage	$V_{RB} = 1.3$ V; $V_{RT} = 3.67$ V; note 4	–	± 0.1	–	%

10-bit high-speed low-power ADC

TDA8763A

SYMBOL	PARAMETER	CONDITIONS	MIN.	TYP.	MAX.	UNIT	
BANDWIDTH ($f_{clk} = 40$ MHz)							
B	analog bandwidth	full-scale sine-wave; note 5	–	18	–	MHz	
		75% full-scale sine-wave; note 5	–	25	–	MHz	
		small signal at mid-scale; $V_1 = \pm 10$ LSB at code 512; note 5	–	350	–	MHz	
t_{STLH}	analog input settling time LOW-to-HIGH	full-scale square-wave; see Fig.6; note 6	–	2.0	3	ns	
t_{STHL}	analog input settling time HIGH-to-LOW	full-scale square-wave; see Fig.6; note 6	–	2.5	3.5	ns	
HARMONICS ($f_{clk} = 40$ MHz); see Figs 7 and 8							
h_1	fundamental harmonics (full-scale)	$f_i = 4.43$ MHz	–	–	0	dB	
h_{all}	harmonics (full-scale); all components	$f_i = 4.43$ MHz	–	–79	–69	dB	
			second harmonics	–	–74	–67	dB
			third harmonics	–	–	–	dB
THD	total harmonic distortion	$f_i = 4.43$ MHz	–	–69	–	dB	
SIGNAL-TO-NOISE RATIO; see Figs 7 and 8; note 7							
S/N	signal-to-noise ratio (full-scale)	without harmonics; $f_{clk} = 40$ MHz; $f_i = 4.43$ MHz	56	58	–	dB	
EFFECTIVE BITS; see Figs 7 and 8; note 7							
EB	effective bits TDA8763AM/3	$f_{clk} = 30$ MHz	–	–	–	–	
		$f_i = 4.43$ MHz	–	9.4	–	bits	
		$f_i = 7.5$ MHz	–	9.1	–	bits	
EB	effective bits TDA8763AM/4	$f_{clk} = 40$ MHz	–	–	–	–	
		$f_i = 4.43$ MHz	–	9.4	–	bits	
		$f_i = 7.5$ MHz	–	9.0	–	bits	
		$f_i = 10$ MHz	–	8.9	–	bits	
EB	effective bits TDA8763AM/5	$f_{clk} = 50$ MHz	–	–	–	–	
		$f_i = 4.43$ MHz	–	9.3	–	bits	
		$f_i = 7.5$ MHz	–	8.9	–	bits	
		$f_i = 10$ MHz	–	8.8	–	bits	
EB	effective bits TDA8763AM/5	$f_i = 15$ MHz	–	8.0	–	bits	

10-bit high-speed low-power ADC

TDA8763A

SYMBOL	PARAMETER	CONDITIONS	MIN.	TYP.	MAX.	UNIT
TWO-TONE; note 8						
TTIR	two-tone intermodulation rejection	$f_{\text{clk}} = 40 \text{ MHz}$	–	–69	–	dB
BIT ERROR RATE						
BER	bit error rate	$f_{\text{clk}} = 50 \text{ MHz};$ $f_i = 4.43 \text{ MHz};$ $V_I = \pm 16 \text{ LSB at code 512}$	–	10^{-13}	–	times/ sample
DIFFERENTIAL GAIN; note 9						
G_{diff}	differential gain	$f_{\text{clk}} = 40 \text{ MHz};$ PAL modulated ramp	–	0.5	–	%
DIFFERENTIAL PHASE; note 9						
ϕ_{diff}	differential phase	$f_{\text{clk}} = 40 \text{ MHz};$ PAL modulated ramp	–	0.3	–	deg
Timing ($f_{\text{clk}} = 40 \text{ MHz}; C_L = 15 \text{ pF}$); see Fig.4; note 10						
t_{ds}	sampling delay time		–	–	2	ns
t_{h}	output hold time		5	–	–	ns
t_{d}	output delay time	$V_{\text{CCO}} = 4.75 \text{ V}$	–	10	13	ns
		$V_{\text{CCO}} = 3.15 \text{ V}$	–	12	15	ns
C_L	digital output load capacitance		–	15	40	pF
3-state output delay times; see Fig.5						
t_{dZH}	enable HIGH		–	14	18	ns
t_{dZL}	enable LOW		–	16	20	ns
t_{dHZ}	disable HIGH		–	16	20	ns
t_{dLZ}	disable LOW		–	14	18	ns

Notes

- In addition to a good layout of the digital and analog ground, it is recommended that the rise and fall times of the clock must not be less than 0.5 ns.
- Analog input voltages producing code 0 up to and including code 1023:
 - V_{osB} (voltage offset BOTTOM) is the difference between the analog input which produces data equal to 00 and the reference voltage BOTTOM (V_{RB}) at $T_{\text{amb}} = 25 \text{ }^\circ\text{C}$.
 - V_{osT} (voltage offset TOP) is the difference between V_{RT} (reference voltage TOP) and the analog input which produces data outputs equal to code 1023 at $T_{\text{amb}} = 25 \text{ }^\circ\text{C}$.
- In order to ensure the optimum linearity performance of such converter architecture the lower and upper extremities of the converter reference resistor ladder (corresponding to output codes 0 and 1023 respectively) are connected to pins V_{RB} and V_{RT} via offset resistors R_{OB} and R_{OT} as shown in Fig.3.

a) The current flowing into the resistor ladder is $I_L = \frac{V_{\text{RT}} - V_{\text{RB}}}{R_{\text{OB}} + R_L + R_{\text{OT}}}$ and the full-scale input range at the converter,

to cover code 0 to code 1023, is $V_I = R_L \times I_L = \frac{R_L}{R_{\text{OB}} + R_L + R_{\text{OT}}} \times (V_{\text{RT}} - V_{\text{RB}}) = 0.852 \times (V_{\text{RT}} - V_{\text{RB}})$

10-bit high-speed low-power ADC

TDA8763A

b) Since R_L , R_{OB} and R_{OT} have similar behaviour with respect to process and temperature variation, the

ratio $\frac{R_L}{R_{OB} + R_L + R_{OT}}$ will be kept reasonably constant from device to device. Consequently variation of the output codes at a given input voltage depends mainly on the difference $V_{RT} - V_{RB}$ and its variation with temperature and supply voltage. When several ADCs are connected in parallel and fed with the same reference source, the matching between each of them is then optimized.

$$4. \text{ GER} = \frac{(V_{1023} - V_0) - 2 V}{2 V} \times 100$$

5. The analog bandwidth is defined as the maximum input sine-wave frequency which can be applied to the device. No glitches greater than 2 LSBs, neither any significant attenuation are observed in the reconstructed signal.
6. The analog input settling time is the minimum time required for the input signal to be stabilized after a sharp full-scale input (square-wave signal) in order to sample the signal and obtain correct output data.
7. Effective bits are obtained via a Fast Fourier Transform (FFT) treatment taking 8K acquisition points per equivalent fundamental period. The calculation takes into account all harmonics and noise up to half of the clock frequency (NYQUIST frequency). Conversion to signal-to-noise ratio: $S/N = EB \times 6.02 + 1.76$ dB.
8. Intermodulation measured relative to either tone with analog input frequencies of 4.43 MHz and 4.53 MHz. The two input signals have the same amplitude and the total amplitude of both signals provides full-scale to the converter.
9. Measurement carried out using video analyser VM700A, where the video analog signal is reconstructed through a digital-to-analog converter.
10. Output data acquisition: the output data is available after the maximum delay time of t_d . For 50 MSPS version it is recommended to have the lowest possible output load.

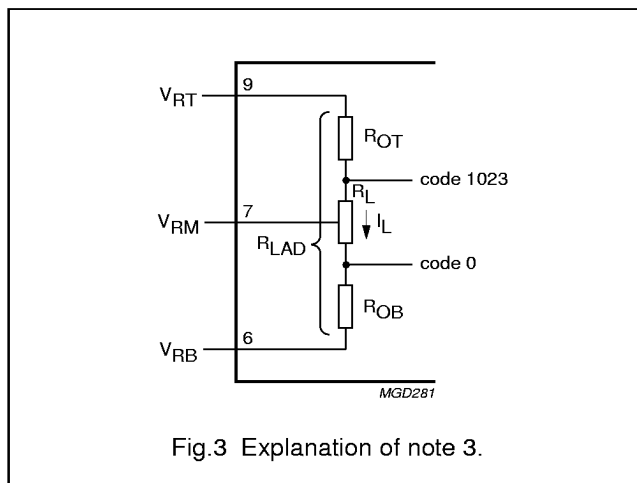

10-bit high-speed low-power ADC

TDA8763A

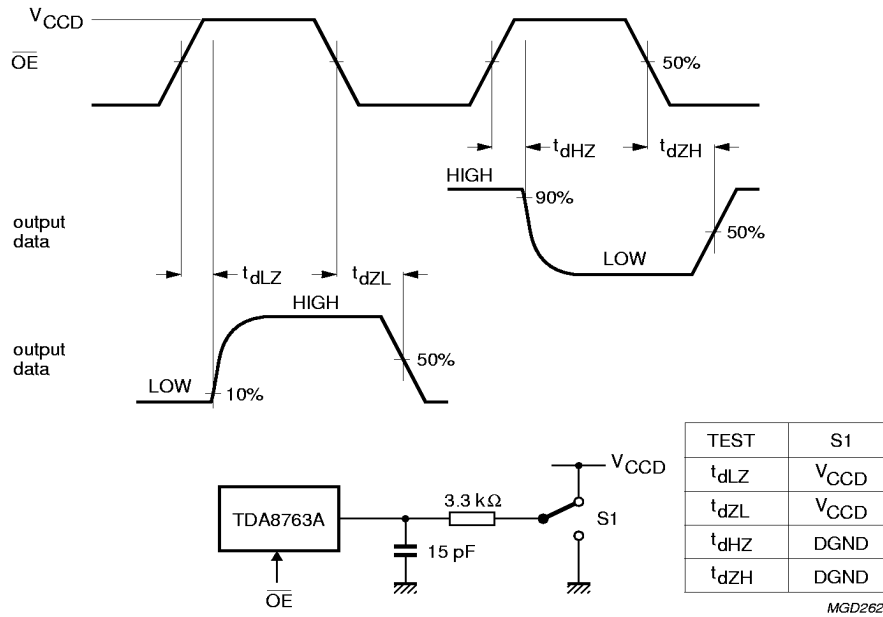

$f_{OE} = 100 \text{ kHz}$.

Fig.5 Timing diagram and test conditions of 3-state output delay time.

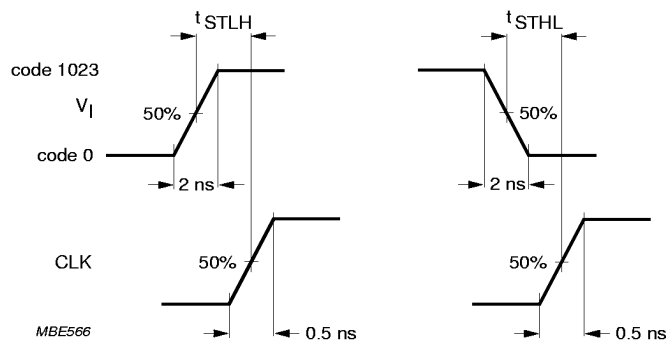
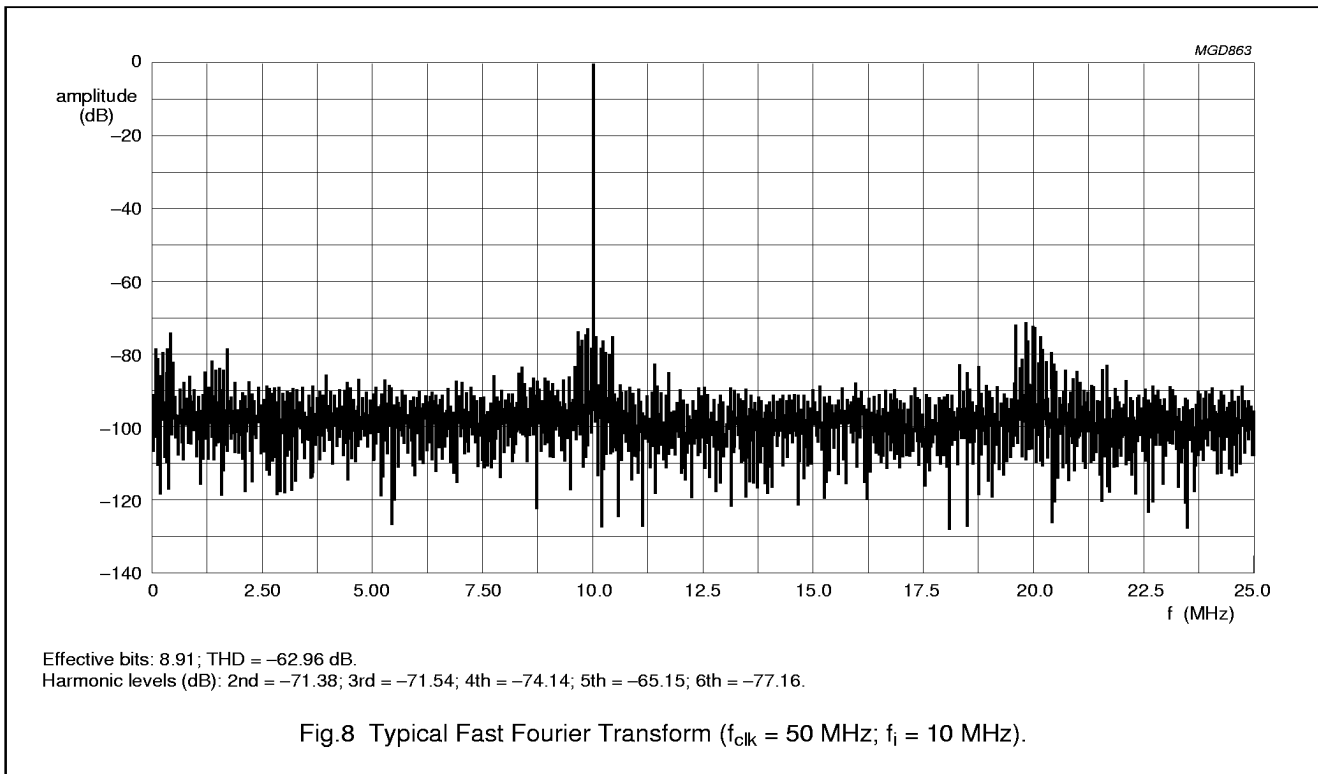
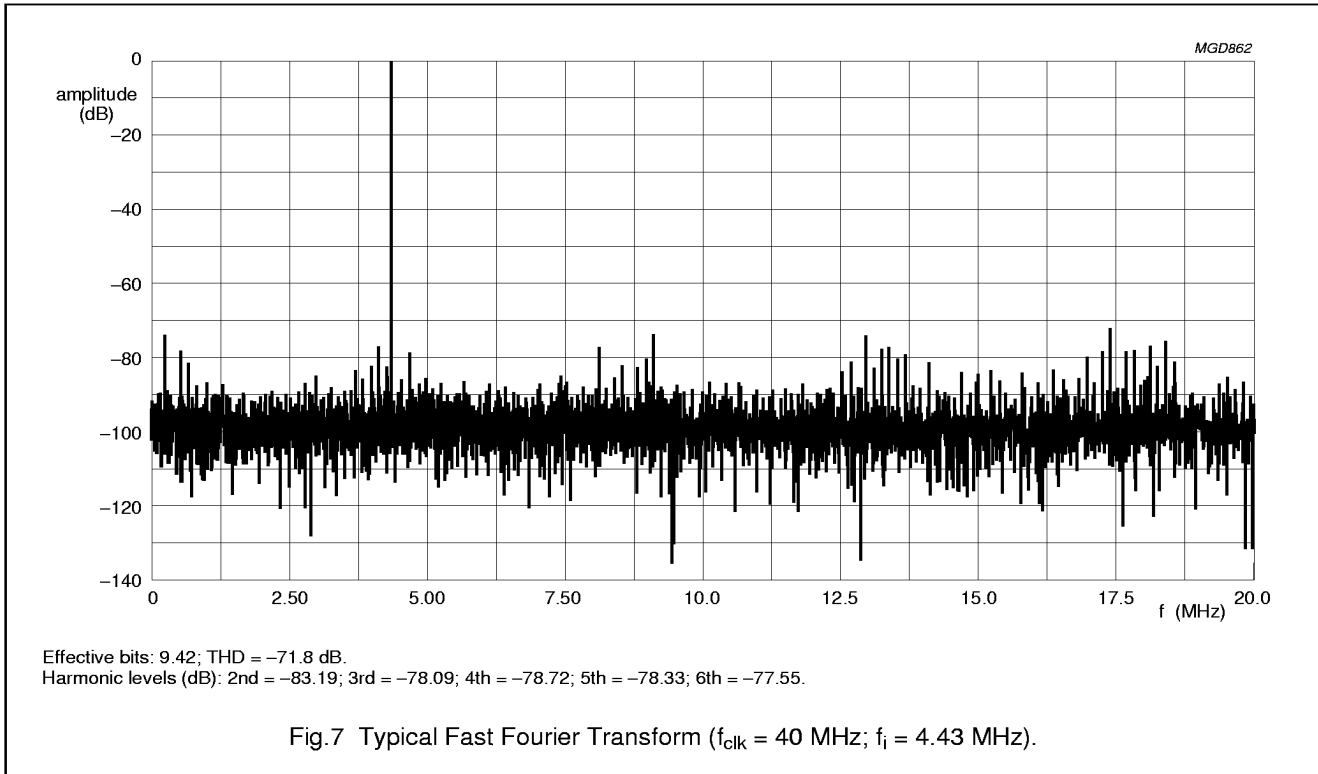

Fig.6 Analog input settling-time diagram.

10-bit high-speed low-power ADC

TDA8763A



10-bit high-speed low-power ADC

TDA8763A

INTERNAL PIN CONFIGURATIONS

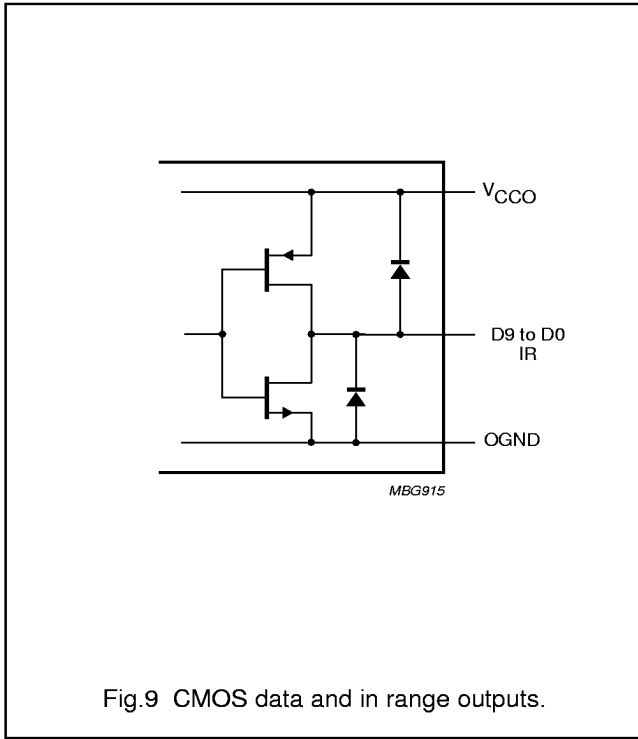

Fig.9 CMOS data and in range outputs.

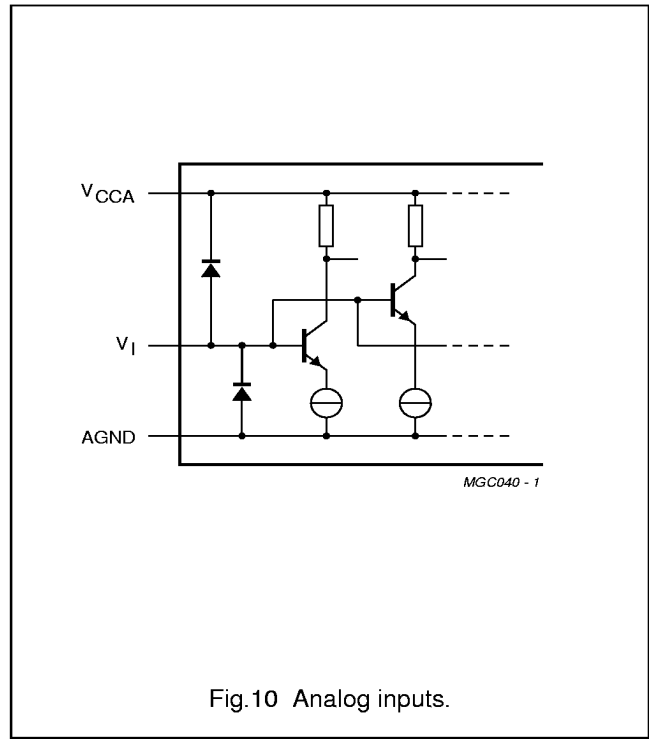

Fig.10 Analog inputs.

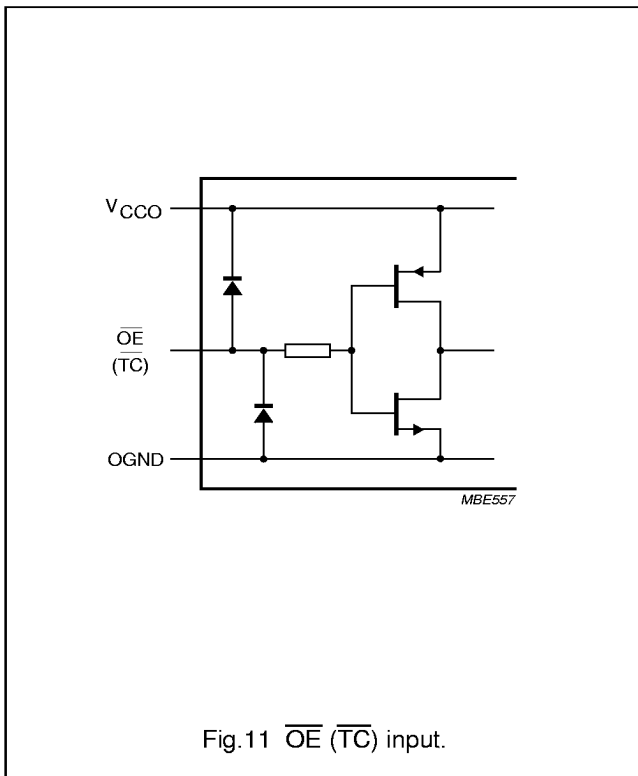

Fig.11 \overline{OE} (\overline{TC}) input.

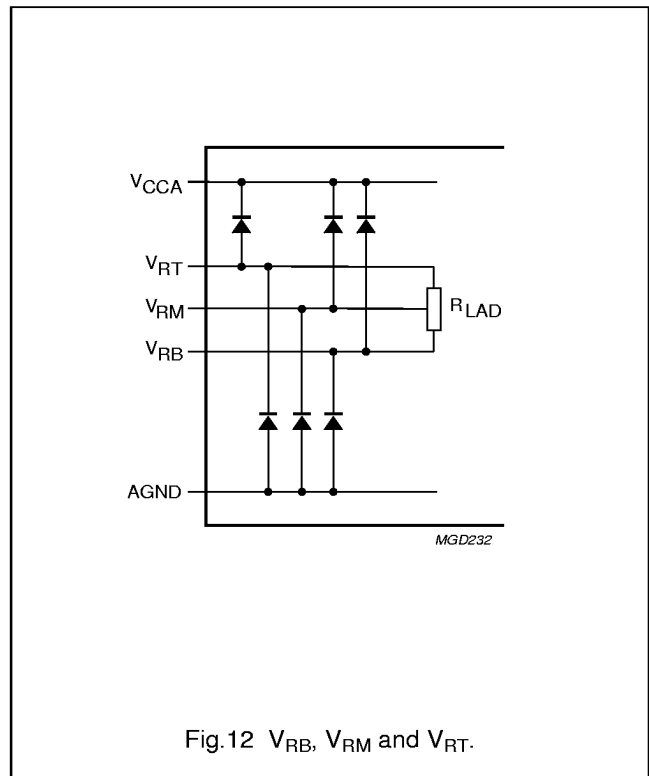
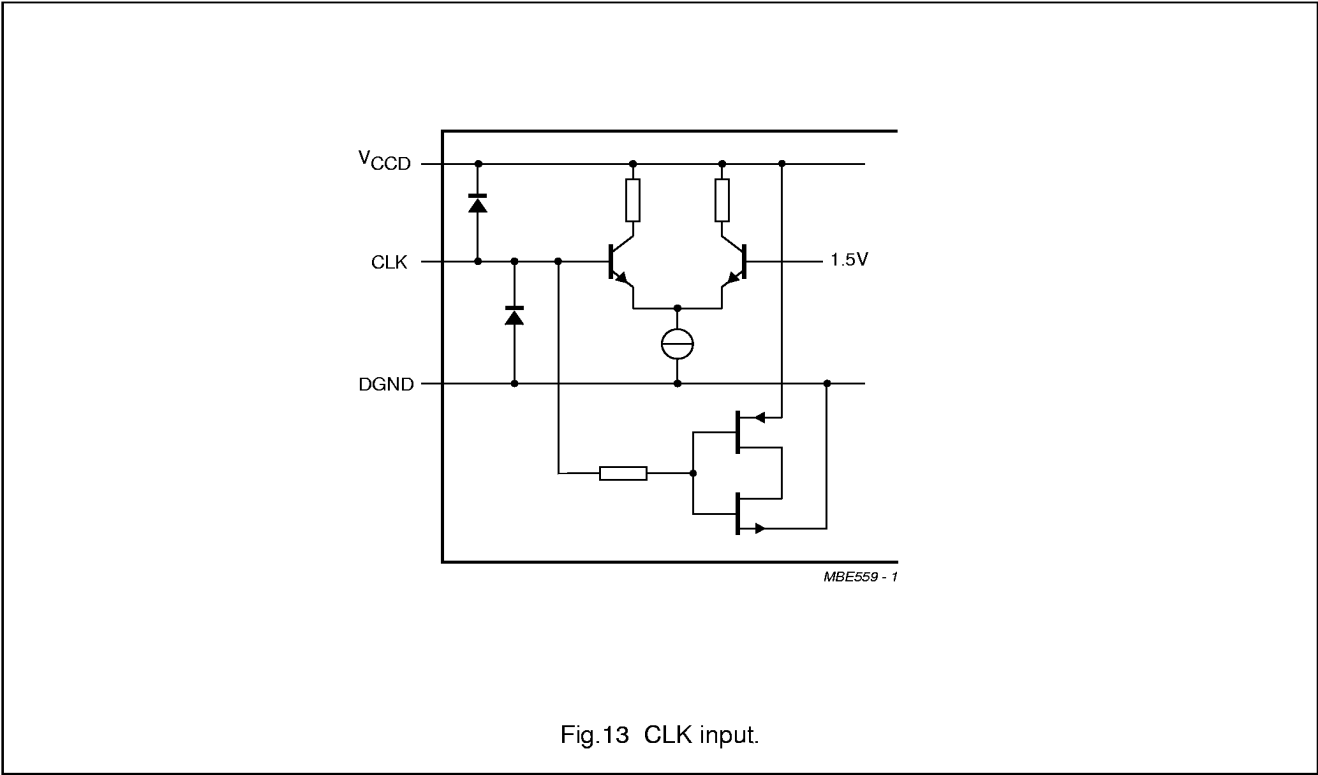

Fig.12 V_{RB} , V_{RM} and V_{RT} .

10-bit high-speed low-power ADC

TDA8763A



10-bit high-speed low-power ADC

TDA8763A

APPLICATION INFORMATION

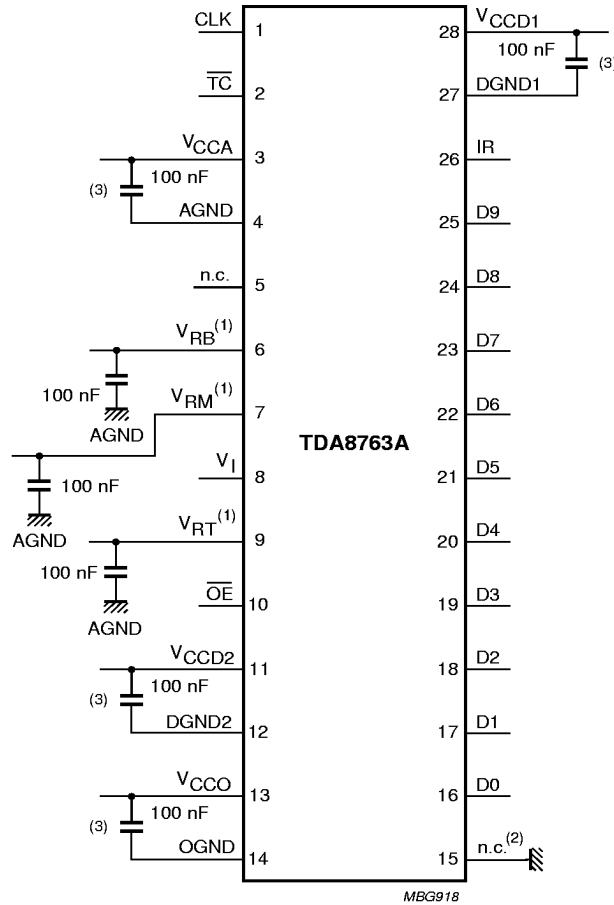

The analog and digital supplies should be separated and well decoupled.

The external voltage regulator must be built such that a good supply voltage ripple rejection is achieved with respect to the LSB value. Eventually, the reference ladder voltages can be derived from a well regulated V_{CCA} supply through a resistor bridge and a decoupled capacitor.

- (1) V_{RB} , V_{RM} and V_{RT} are decoupled to AGND.
- (2) Pin 15 should be connected to DGND in order to prevent noise influence.
- (3) Decoupling capacitor for supplies; it must be placed close to the device.

Fig.14 Application diagram.

10-bit high-speed low-power ADC

TDA8763A

PACKAGE OUTLINE

SSOP28: plastic shrink small outline package; 28 leads; body width 5.3 mm

SOT341-1

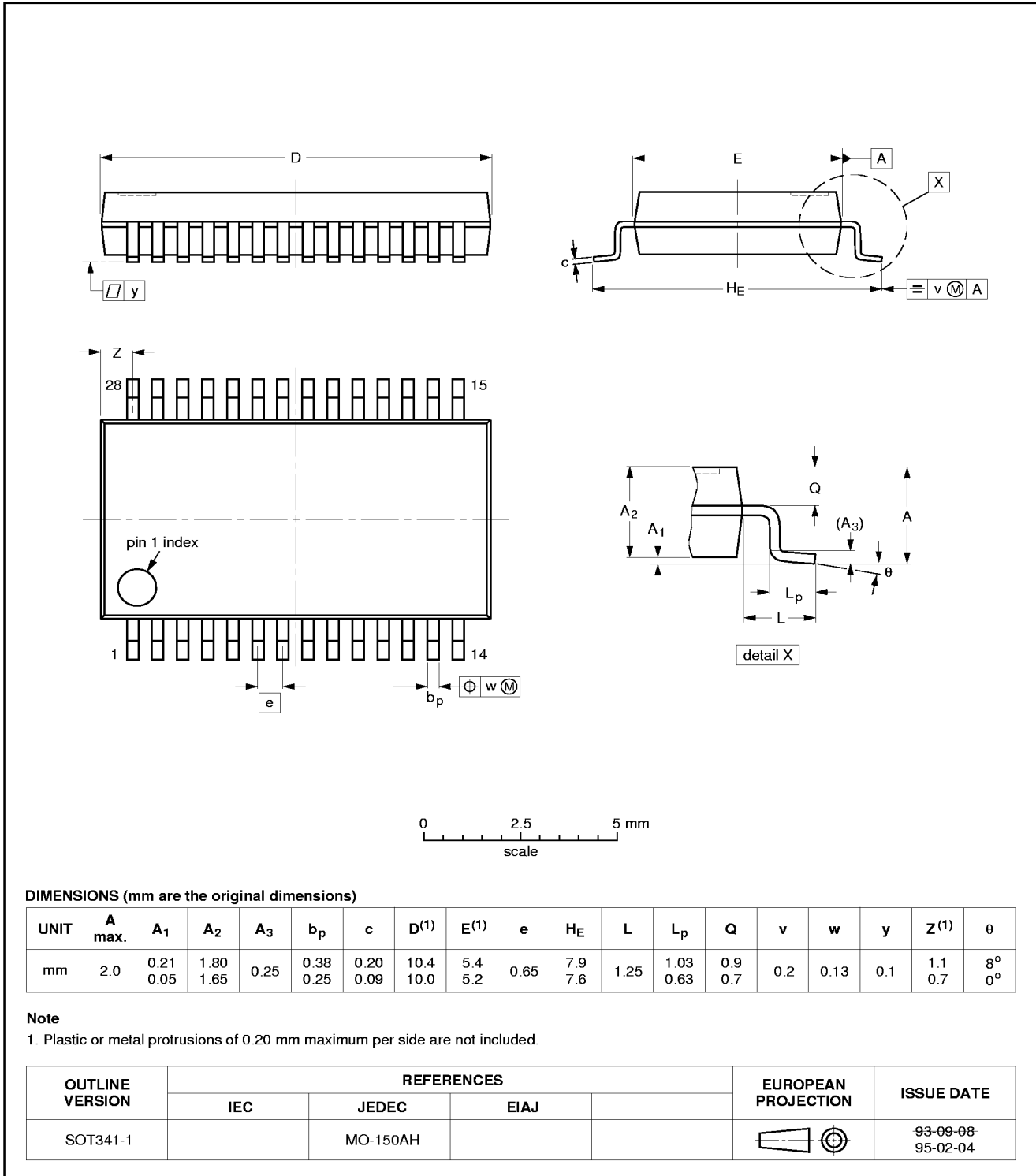

10-bit high-speed low-power ADC

TDA8763A

SOLDERING

Introduction

There is no soldering method that is ideal for all IC packages. Wave soldering is often preferred when through-hole and surface mounted components are mixed on one printed-circuit board. However, wave soldering is not always suitable for surface mounted ICs, or for printed-circuits with high population densities. In these situations reflow soldering is often used.

This text gives a very brief insight to a complex technology. A more in-depth account of soldering ICs can be found in our *"IC Package Databook"* (order code 9398 652 90011).

Reflow soldering

Reflow soldering techniques are suitable for all SSOP packages.

Reflow soldering requires solder paste (a suspension of fine solder particles, flux and binding agent) to be applied to the printed-circuit board by screen printing, stencilling or pressure-syringe dispensing before package placement.

Several techniques exist for reflowing; for example, thermal conduction by heated belt. Dwell times vary between 50 and 300 seconds depending on heating method. Typical reflow temperatures range from 215 to 250 °C.

Preheating is necessary to dry the paste and evaporate the binding agent. Preheating duration: 45 minutes at 45 °C.

Wave soldering

Wave soldering is **not** recommended for SSOP packages. This is because of the likelihood of solder bridging due to closely-spaced leads and the possibility of incomplete solder penetration in multi-lead devices.

If wave soldering cannot be avoided, the following conditions must be observed:

- **A double-wave (a turbulent wave with high upward pressure followed by a smooth laminar wave) soldering technique should be used.**
- **The longitudinal axis of the package footprint must be parallel to the solder flow and must incorporate solder thieves at the downstream end.**

Even with these conditions, only consider wave soldering SSOP packages that have a body width of 4.4 mm, that is SSOP16 (SOT369-1) or SSOP20 (SOT266-1).

During placement and before soldering, the package must be fixed with a droplet of adhesive. The adhesive can be applied by screen printing, pin transfer or syringe dispensing. The package can be soldered after the adhesive is cured.

Maximum permissible solder temperature is 260 °C, and maximum duration of package immersion in solder is 10 seconds, if cooled to less than 150 °C within 6 seconds. Typical dwell time is 4 seconds at 250 °C.

A mildly-activated flux will eliminate the need for removal of corrosive residues in most applications.

Repairing soldered joints

Fix the component by first soldering two diagonally-opposite end leads. Use only a low voltage soldering iron (less than 24 V) applied to the flat part of the lead. Contact time must be limited to 10 seconds at up to 300 °C. When using a dedicated tool, all other leads can be soldered in one operation within 2 to 5 seconds between 270 and 320 °C.