

Digital controlled stereo audio processor with loudness

Features

- Input multiplexer:
 - 3 stereo inputs
 - Selectable input gain for optimal adaption to different sources
- Volume control in 1.25dB steps
- Loudness function
- Treble and bass control
- Four speaker attenuatorS:
 - 4 independent speakers control in 1.25dB steps for balance and fader facilities
 - Independent mute function
- All functions programmable via serial I²C bus

Description

The TDA7303 is a volume, tone (bass and treble) balance (Left/Right) and fader (front/rear) processor for quality audio applications in car radio, Hi-Fi and portable systems.

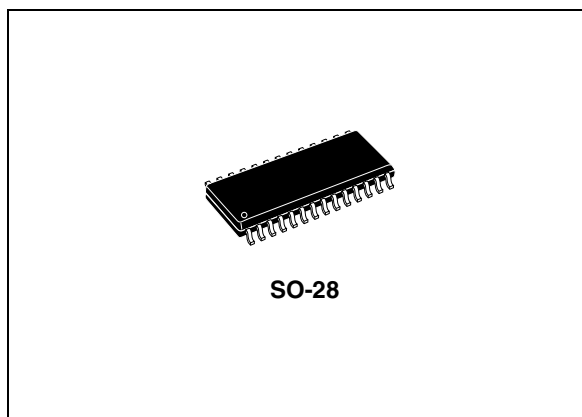

Selectable input gain and external loudness function are provided. Control is accomplished by serial I²C bus microprocessor interface.

The AC signal setting is obtained by resistor networks and switches combined with operational amplifiers.

Thanks to the used BIPOLAR/CMOS Tecnology, Low Distortion, Low Noise and Low DC stepping are obtained.

Order codes

Part number	Package	Packing
TDA7303	SO-28	Tray
TDA7303TR	SO-28	Tape and reel

Contents

- 1 Block, test & pins diagrams 5**
 - 1.1 Block diagram 5
 - 1.2 Test circuit 6
 - 1.3 Pins connection 6

- 2 Electrical specifications 7**
 - 2.1 Absolute maximum ratings 7
 - 2.2 Quick reference data 7
 - 2.3 Thermal data 7
 - 2.4 Electrical characteristics 8
 - 2.5 Electrical characteristics curves 10

- 3 I2C bus interface 13**
 - 3.1 Data validity 13
 - 3.2 Start and stop conditions 13
 - 3.3 Byte format 13
 - 3.4 Acknowledge 13
 - 3.5 Transmission without acknowledge 13

- 4 Software specification 15**
 - 4.1 Interface Protocol 15
 - 4.2 Subaddress (receive mode) 15
 - 4.3 Data bytes (detailed description) 16

- 5 Package information 18**

- 6 Revision history 19**

List of tables

Table 1.	Absolute maximum ratings	7
Table 2.	Quick reference data	7
Table 3.	Thermal data	7
Table 4.	Electrical Characteristics	8
Table 5.	Chip address	15
Table 6.	Data bytes	15
Table 7.	Volume	16
Table 8.	Speaker attenuators	16
Table 9.	Audio switch	17
Table 10.	Bass and Treble	17
Table 11.	Document revision history	19

List of figures

Figure 1.	Block diagram	5
Figure 2.	Test Circuit	6
Figure 3.	Pin Connection (Top view)	6
Figure 4.	Loudness vs Volume Attenuation	10
Figure 5.	Loudness vs. Frequency (CLOUD = 100nF) vs. Volume Attenuation	10
Figure 6.	Loudness versus External Capacitors	10
Figure 7.	Noise versus Volume/Gain Setting	10
Figure 8.	Signal to Noise Ratio vs. Volume Setting	10
Figure 9.	Distortion & Noise vs. Frequency	10
Figure 10.	Signal to Noise Ratio vs. Volume Setting	11
Figure 11.	Distortion vs. Load Resistance	11
Figure 12.	Channel Separation (L Æ R) vs. Frequency.	11
Figure 13.	Input Separation (L1 Æ L2, L3) vs. Frequency.	11
Figure 14.	Supply Voltage Rejection vs. Frequency	11
Figure 15.	Output Clipping Level vs. Supply Voltage.	11
Figure 16.	Quiescent Current vs. Supply Voltage	12
Figure 17.	Supply Current vs. Temperature.	12
Figure 18.	Bass Resistance vs. Temperature	12
Figure 19.	Typical Tone Response (with the ext. components indicated in the test circuit).	12
Figure 20.	Data validity on the I2C bus	14
Figure 21.	Timing diagram of S-bus and I2C bus	14
Figure 22.	Acknowledge on the I2C bus	14
Figure 23.	SO-28 Mechanical Data & Package Dimensions	18

1 Block, test & pins diagrams

1.1 Block diagram

Figure 1. Block diagram

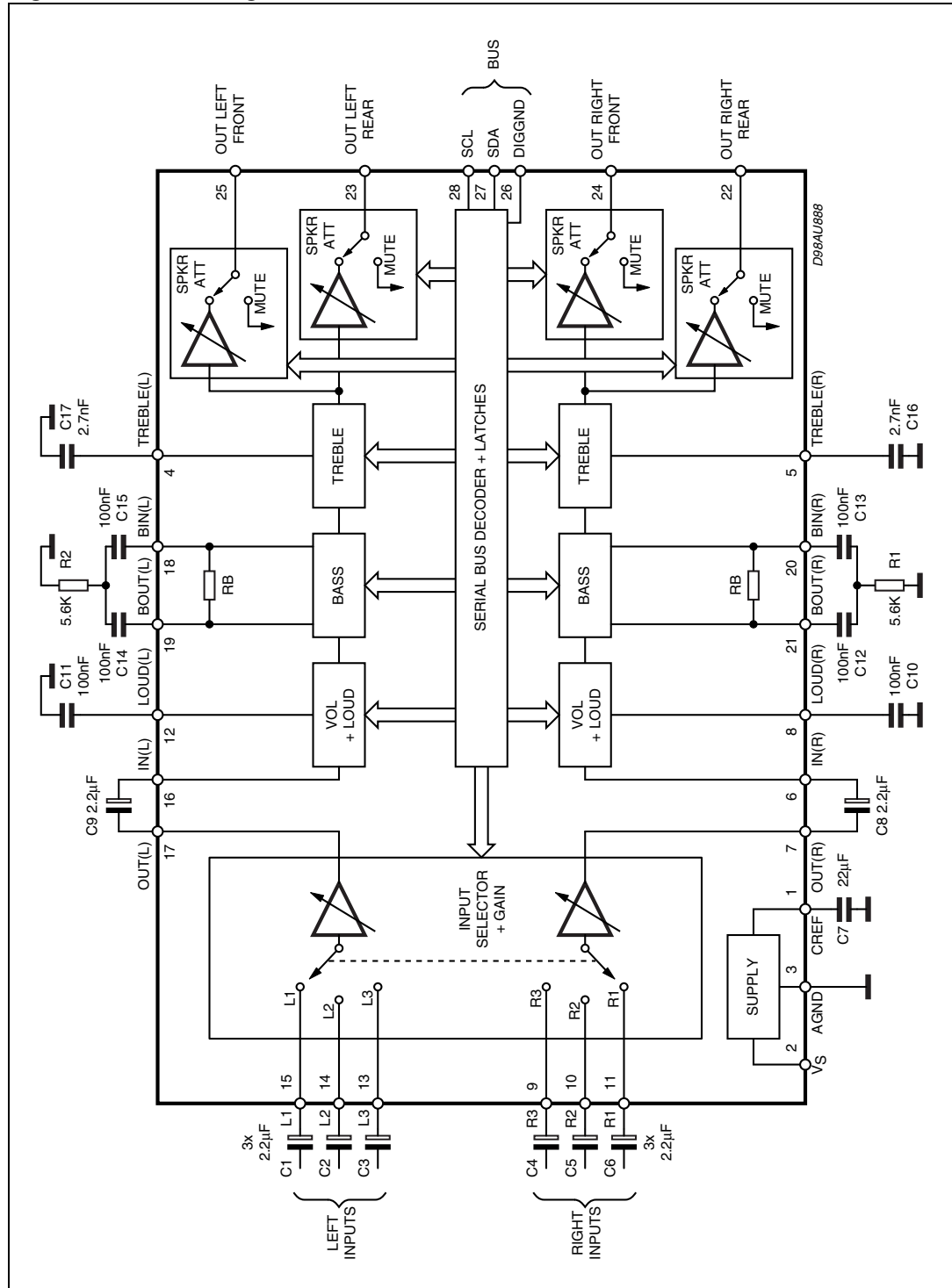

1.2 Test circuit

Figure 2. Test Circuit

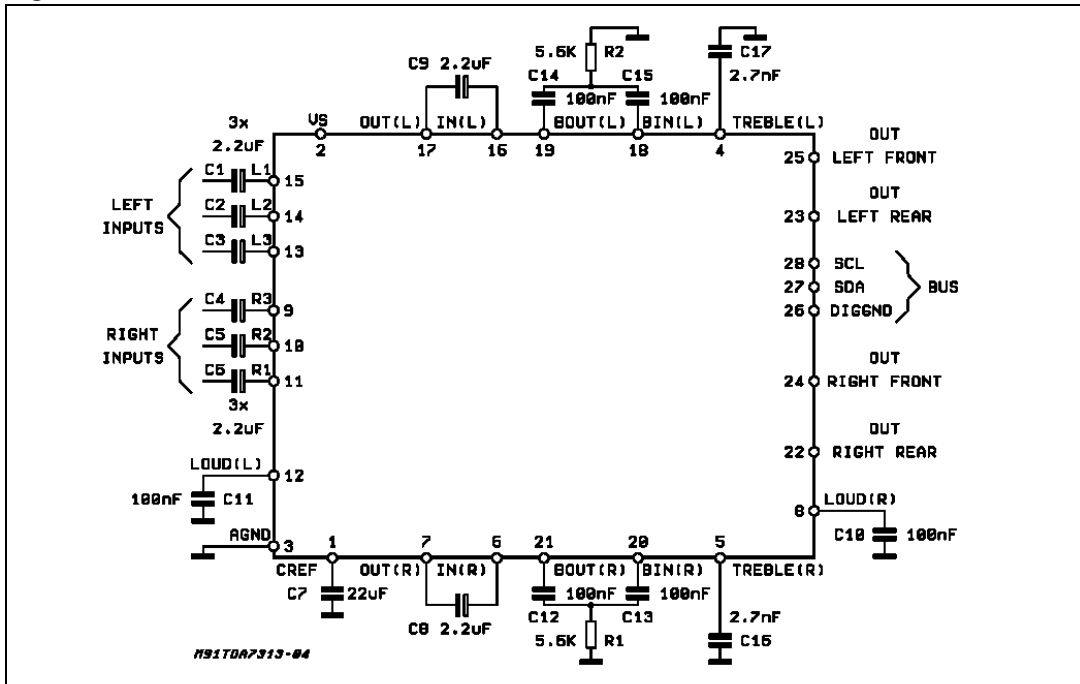

1.3 Pins connection

Figure 3. Pin Connection (Top view)

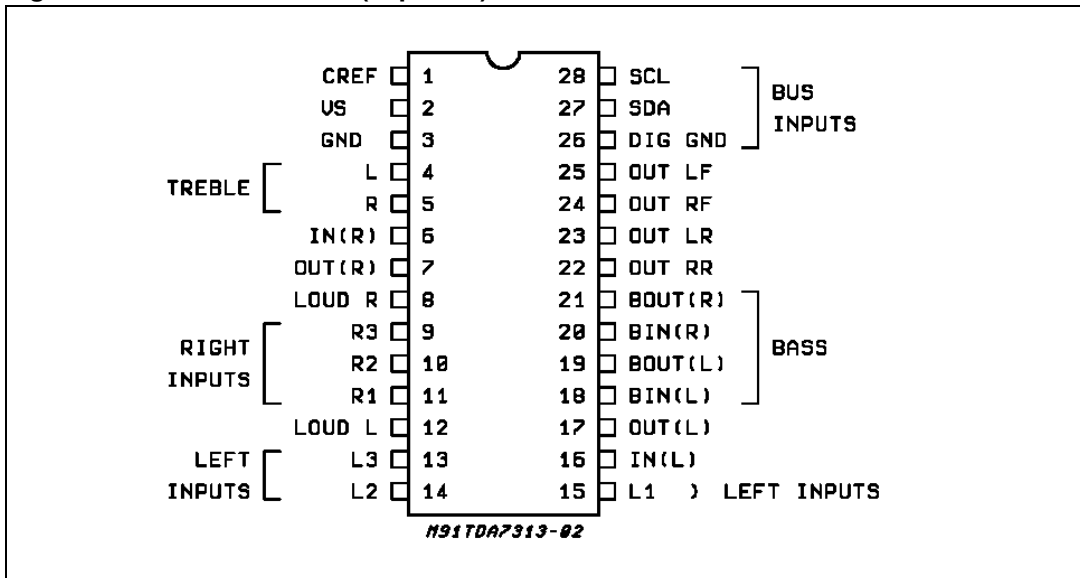

2 Electrical specifications

2.1 Absolute maximum ratings

Table 1. Absolute maximum ratings

Symbol	Parameter	Value	Unit
V _S	Operating Supply Voltage	10.0	V
T _{amb}	Ambient Temperature	-40 to 85	°C
T _{stg}	Storage Temperature Range	-55 to +150	°C

2.2 Quick reference data

Table 2. Quick reference data

Symbol	Parameter	Min.	Typ.	Max.	Unit
V _S	Supply Voltage	6	9	10	V
V _{CL}	Max. input signal handling	2			V _{rms}
THD	Total Harmonic Distortion V = 1V _{rms} f = 1KHz		0.01		%
S/N	Signal to Noise Ratio		106		dB
S _C	Channel Separation f = 1KHz		103		dB
	Volume Control 1.25dB step	-78.75		0	dB
	Bass and Treble Control 2dB step	-14		+14	dB
	Fader and Balance Control 1.25dB step	-38.75		0	dB
	Input gain 3.75db step1.25dB step	0		11.25	dB
	Mute Attenuation		100		dB

2.3 Thermal data

Table 3. Thermal data

Symbol	Parameter	Value	Unit
R _{th j-pins}	Thermal Resistance Junction-pins	max 85	°C/W

2.4 Electrical characteristics

Table 4. Electrical Characteristics
($T_{amb} = 25^{\circ}\text{C}$, $V_S = 9\text{V}$, $R_L = 10\text{K}\Omega$, $R_G = 600\Omega$, all control flat ($G=0$), $f = 1\text{KHz}$ unless otherwise specified)

Symbol	Parameter	Test Condition	Min.	Typ.	Max.	Unit
SUPPLY						
V_S	Supply Voltage		6	9	10	V
I_S	Supply Current			8	11	mA
SVR	Ripple Rejection		60	80		dB
INPUT SELECTORS						
R_{II}	Input Resistance	Input 1, 2, 3, 4		50		$\text{K}\Omega$
V_{CL}	Clipping Level		2	2.5		V_{rms}
S_{IN}	Input Separation (2)		80	100		dB
R_L	Output Load resistance	pin 7, 17	2			$\text{K}\Omega$
G_{INmin}	Min. Input Gain		-1	0	1	dB
G_{INmax}	Max. Input Gain			11.25		dB
G_{STEP}	Step Resolution			3.75		dB
e_{IN}	Input Noise	$G = 11.25\text{dB}$		2		μV
VOLUME CONTROL						
R_{IN}	Input Resistance			33		$\text{k}\Omega$
C_{RANGE}	Control Range		70	75	80	dB
A_{VMIN}	Min. Attenuation		-1	0	1	dB
A_{VMAX}	Max. Attenuation		70	75	80	dB
A_{STEP}	Step Resolution		0.5	1.25	1.75	dB
E_A	Attenuation Set Error	$A_V = 0$ to -20dB	-1.25	0	1.25	dB
		$A_V = -20$ to -60dB	-3		2	dB
E_T	Tracking Error				2	dB
SPEAKER ATTENUATORS						
C_{range}	Control Range		35	37.5	40	dB
S_{STEP}	Step Resolution		0.5	1.25	1.75	dB
E_A	Attenuation set error				1.5	dB
A_{MUTE}	Output Mute Attenuation		80	100		dB
BASS CONTROL⁽¹⁾						
G_b	Control Range	Max. Boost/cut	± 12	± 14	± 16	dB
B_{STEP}	Step Resolution		1	2	3	dB

Table 4. Electrical Characteristics (continued)
 ($T_{amb} = 25^{\circ}\text{C}$, $V_S = 9\text{V}$, $R_L = 10\text{K}\Omega$, $R_G = 600\Omega$, all control flat ($G=0$), $f = 1\text{KHz}$ unless otherwise specified)

Symbol	Parameter	Test Condition	Min.	Typ.	Max.	Unit
R_B	Internal Feedback Resistance			44		$\text{K}\Omega$
TREBLE CONTROL (1)						
G_t	Control Range	Max. Boost/cut	± 13	± 14	± 15	dB
T_{STEP}	Step Resolution		1	2	3	dB
AUDIO OUTPUTS						
V_{OCL}	Clipping Level	$d = 0.3\%$	2	2.5		Vrms
R_L	Output Load Resistance		2			$\text{K}\Omega$
C_L	Output Load Capacitance				10	nF
R_{OUT}	Output resistance			75		W
V_{OUT}	DC Voltage Level		4.2	4.5	4.8	V
GENERAL						
e_{NO}	Output Noise ⁽²⁾	BW = 20-20KHz, flat output muted all gains = 0dB		2.5 5		μV μV
		A curve all gains = 0dB		3		μV
S/N	Signal to Noise Ratio	all gains = 0dB; $V_O = 1\text{Vrms}$		106		dB
d	Distortion	$A_V = 0$; $V_{IN} = 1\text{Vrms}$		0.01		%
		$A_V = 20\text{dB}$, $V_{IN} = 1\text{Vrms}$		0.09	0.3	%
		$A_V = 20\text{dB}$, $V_{IN} = 1\text{Vrms}$		0.04		%
Sc	Channel Separation left/right		80	103		dB
	Total Tracking error	$A_V = 0$ to -20dB		0	1	dB
		-20 to -60 dB		0	2	dB
BUS INPUTS						
V_{IL}	Input Low Voltage				1	V
V_{IH}	Input High Voltage		3			V
I_{IN}	Input Current		-5		+5	μA
V_O	Output Voltage SDA Acknowledge	$I_O = 1.6\text{mA}$			0.4	V

1. Bass and Treble response see attached diagram (fig.22). The center frequency and quality of the resonance behaviour can be chosen by the external circuitry. A standard first order bass response can be realized by a standard feedback network
2. The selected input is grounded thru the $2.2\mu\text{F}$ capacitor.

2.5 Electrical characteristics curves

Figure 4. Loudness vs Volume Attenuation

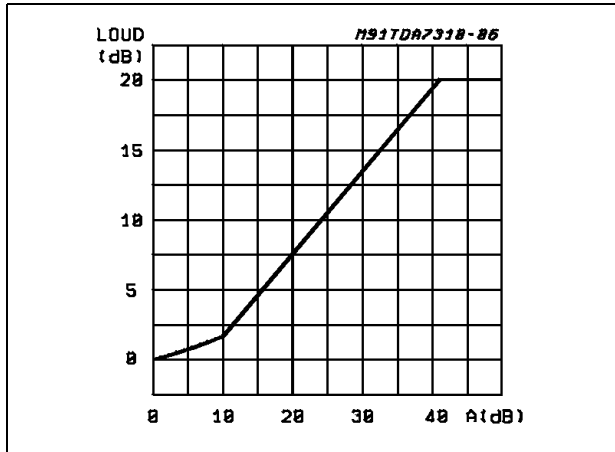

Figure 5. Loudness vs. Frequency ($C_{LOUD} = 100nF$) vs. Volume Attenuation

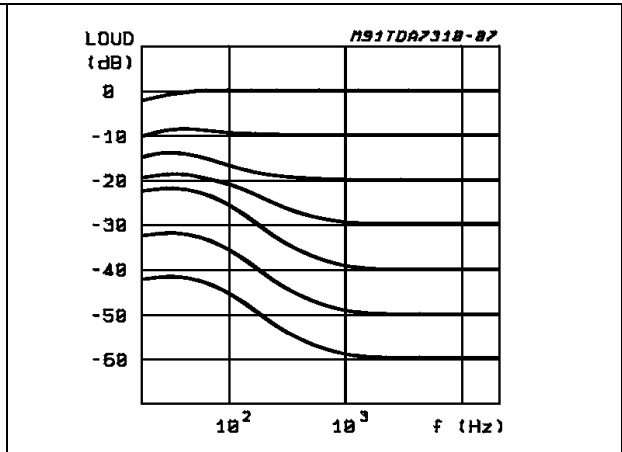

Figure 6. Loudness versus External Capacitors

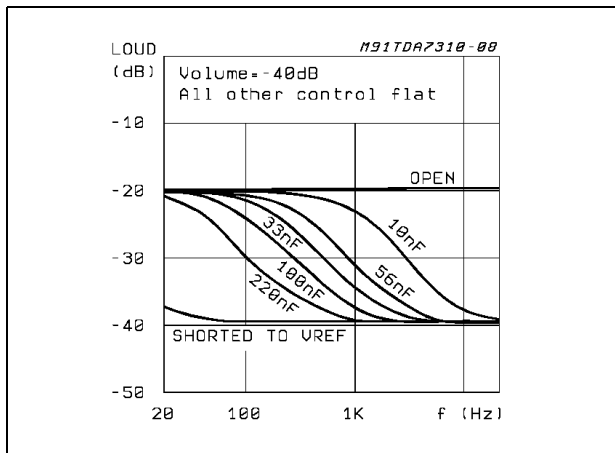

Figure 7. Noise versus Volume/Gain Setting

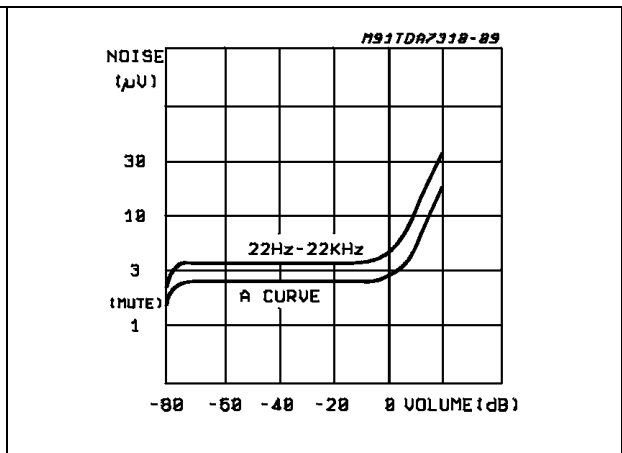

Figure 8. Signal to Noise Ratio vs. Volume Setting

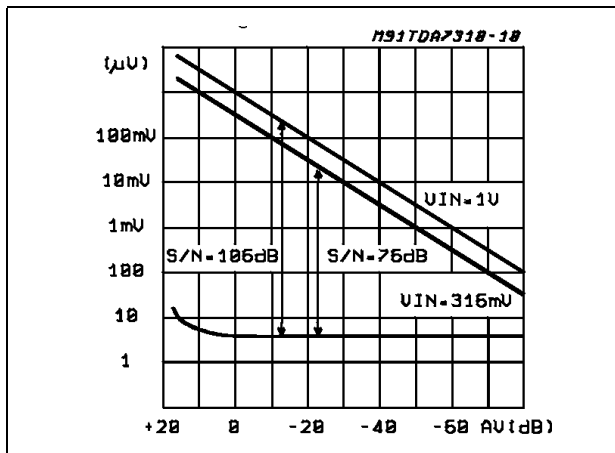

Figure 9. Distortion & Noise vs. Frequency

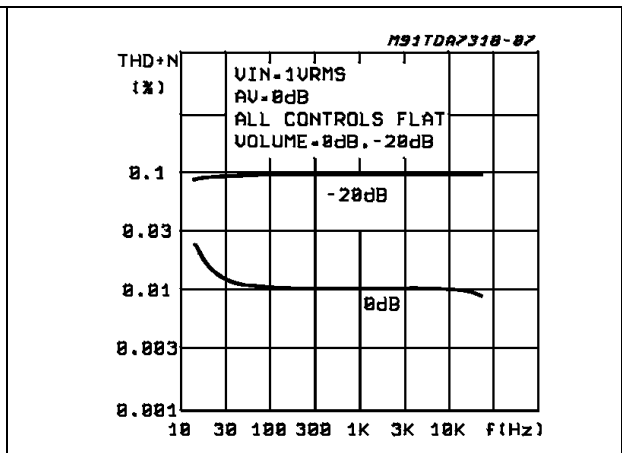

Figure 10. Signal to Noise Ratio vs. Volume Setting

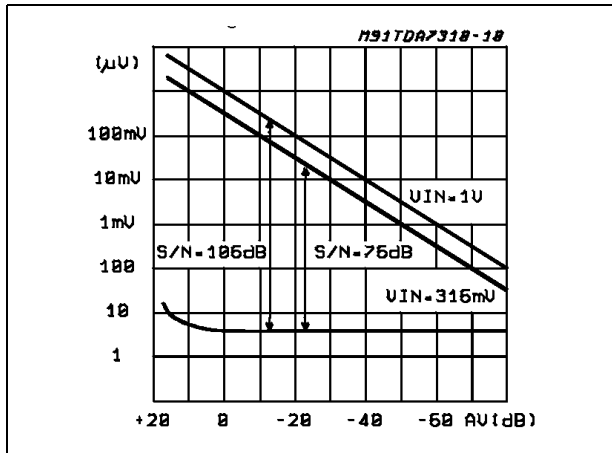

Figure 11. Distortion vs. Load Resistance

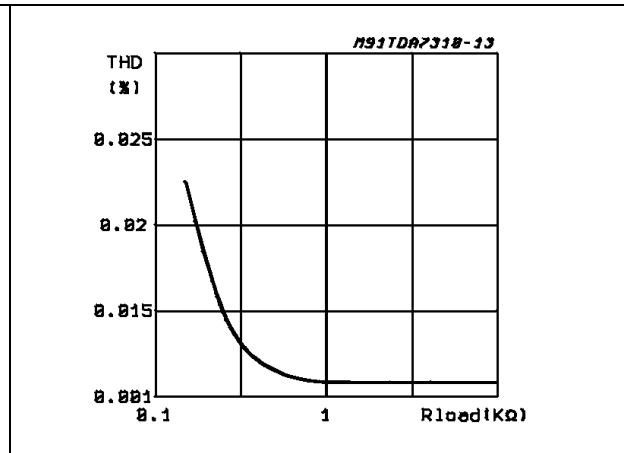

Figure 12. Channel Separation (L → R) vs. Frequency

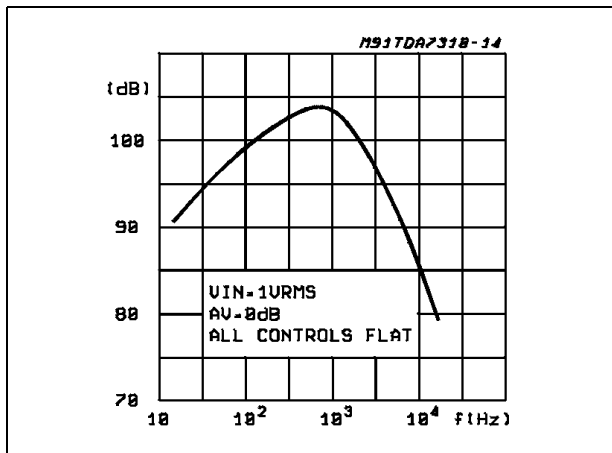

Figure 13. Input Separation (L1 → L2, L3) vs. Frequency

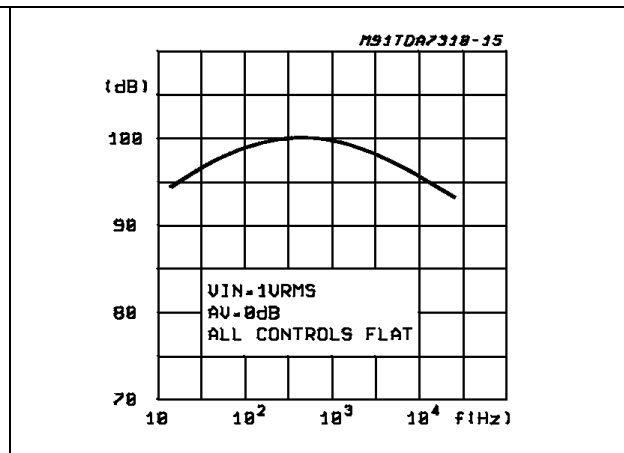

Figure 14. Supply Voltage Rejection vs. Frequency

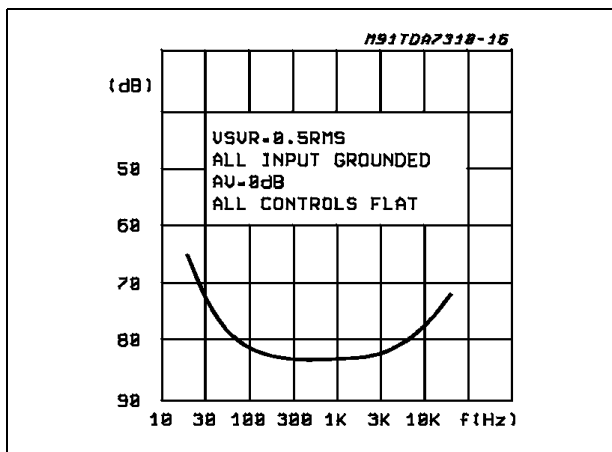

Figure 15. Output Clipping Level vs. Supply Voltage

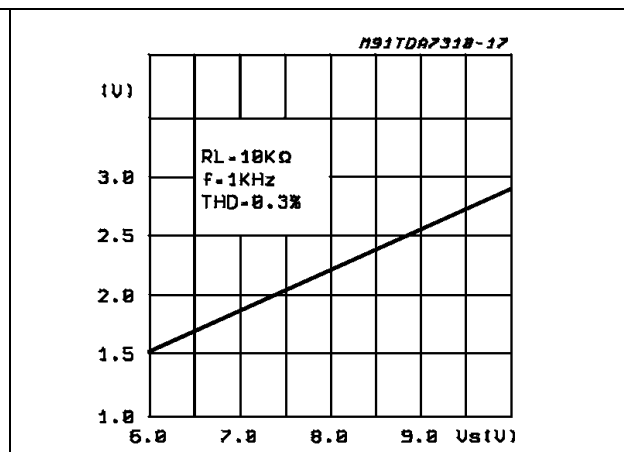

Figure 16. Quiescent Current vs. Supply Voltage

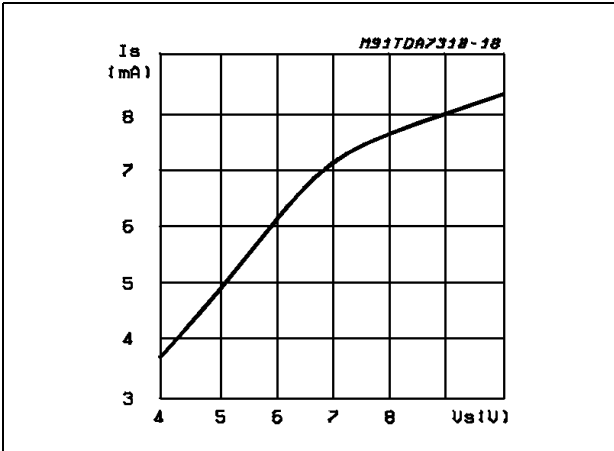

Figure 17. Supply Current vs. Temperature

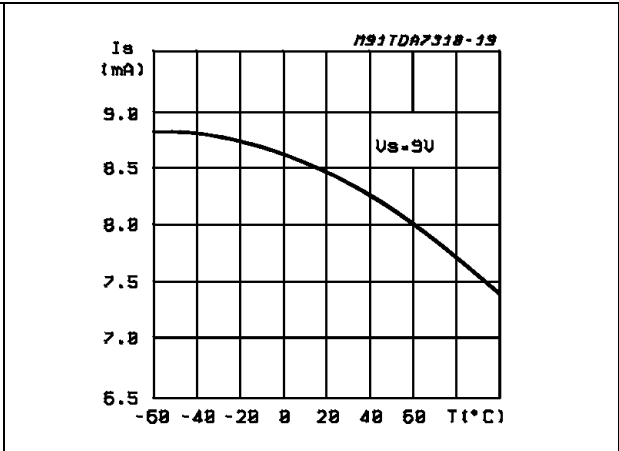

Figure 18. Bass Resistance vs. Temperature

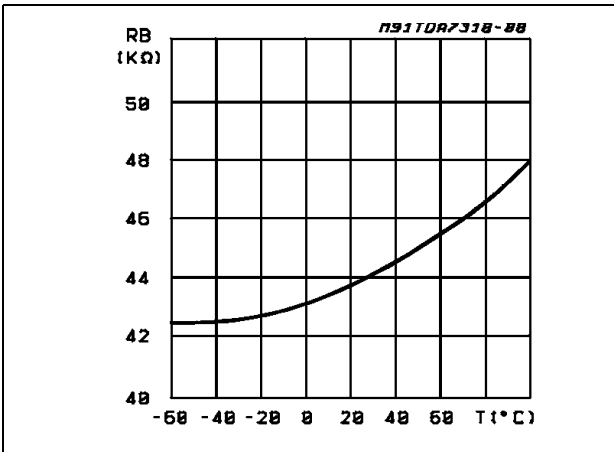
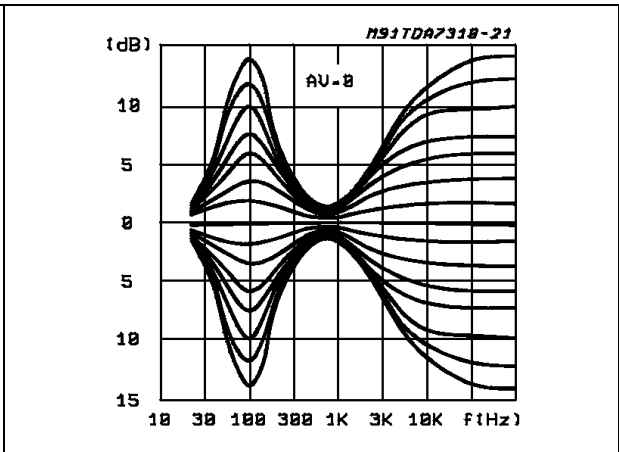

Figure 19. Typical Tone Response (with the ext. components indicated in the test circuit)



3 I²C bus interface

Data transmission from microprocessor to the TDA7303 and viceversa takes place thru the 2 wires I²C BUS interface, consisting of the two lines SDA and SCL (pull-up resistors to positive supply voltage must be connected).

3.1 Data validity

As shown in [Figure 20](#), the data on the SDA line must be stable during the high period of the clock. The HIGH and LOW state of the data line can only change when the clock signal on the SCL line is LOW.

3.2 Start and stop conditions

As shown in [Figure 21](#) a start condition is a HIGH to LOW transition of the SDA line while SCL is HIGH. The stop condition is a LOW to HIGH transition of the SDA line while SCL is HIGH.

3.3 Byte format

Every byte transferred on the SDA line must contain 8 bits. Each byte must be followed by an acknowledge bit. The MSB is transferred first.

3.4 Acknowledge

The master (μ P) puts a resistive HIGH level on the SDA line during the acknowledge clock pulse (see [Figure 22](#)). The peripheral (audioprocessor) that acknowledges has to pull-down (LOW) the SDA line during the acknowledge clock pulse, so that the SDA line is stable LOW during this clock pulse.

The audioprocessor which has been addressed has to generate an acknowledge after the reception of each byte, otherwise the SDA line remains at the HIGH level during the ninth clock pulse time. In this case the master transmitter can generate the STOP information in order to abort the transfer.

3.5 Transmission without acknowledge

Avoiding to detect the acknowledge of the audioprocessor, the μ P can use a simpler transmission: simply it waits one clock without checking the slave acknowledging, and sends the new data.

This approach of course is less protected from misworking and decreases the noise immunity.

Figure 20. Data validity on the I²C bus

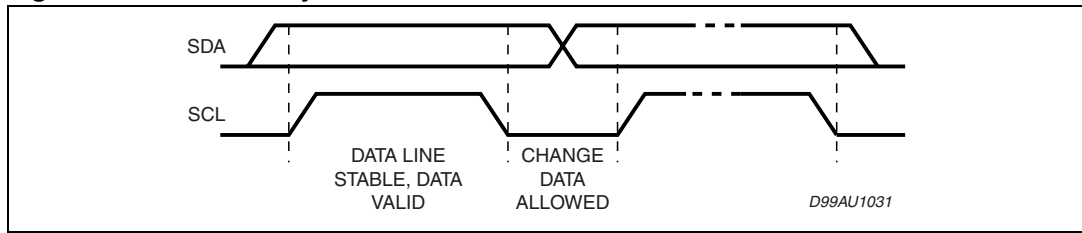

Figure 21. Timing diagram of S-bus and I²C bus

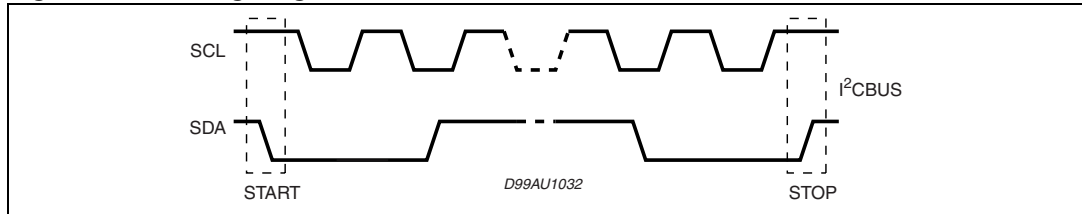
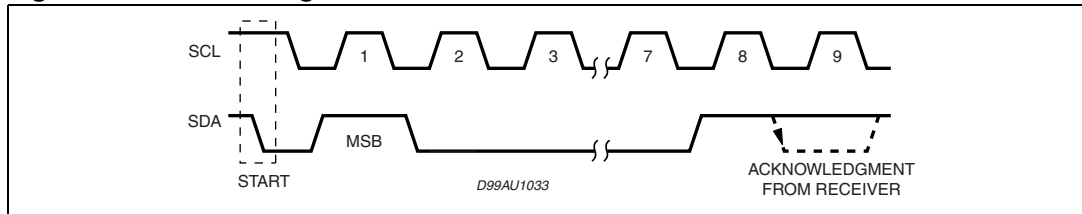

Figure 22. Acknowledge on the I²C bus



Patent note: Purchase of I²C Components of STMicroelectronics, conveys a license under the Philips I²C Patent Rights to use these components in an I²C system, provided that the system conforms to the I²C Standard Specifications as defined by Philips.

4 Software specification

4.1 Interface Protocol

The interface protocol comprises:

- A start condition (s)
- A chip address byte, containing the TDA7303 address (the 8th bit of the byte must be 0).
The TDA7303 must always acknowledge at the end of each transmitted byte.
- A sequence of data (N-bytes + acknowledge)
- A stop condition (P)

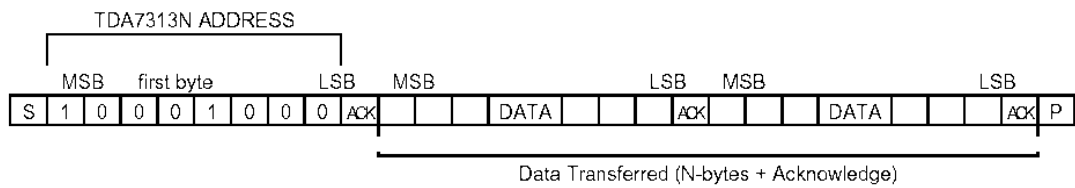

ACK = Acknowledge

S = Start

P = Stop

MAX CLOCK SPEED 100kbits/s

4.2 Subaddress (receive mode)

Table 5. Chip address

1 MSB	0	0	0	1	0	0	0 LSB
----------	---	---	---	---	---	---	----------

Table 6. Data bytes

MSB		LSB						FUNCTION
0	0	B2	B1	B0	A2	A1	A0	Volume control
1	1	0	B1	B0	A2	A1	A0	Speaker ATT LR
1	1	1	B1	B0	A2	A1	A0	Speaker ATT RR
1	0	0	B1	B0	A2	A1	A0	Speaker ATT LF
1	0	1	B1	B0	A2	A1	A0	Speaker ATT RF
0	1	0	G1	G0	S2	S1	S0	Audio switch
0	1	1	0	C3	C2	C1	C0	Bass control
0	1	1	1	C3	C2	C1	C0	Treble control

Ax = 1.25dB steps; Bx = 10dB steps; Cx = 2dB steps; Gx = 3.75dB steps

4.3 Data bytes (detailed description)

Table 7. Volume

MSB					LSB			FUNCTION
0	0	B2	B1	B0	A2	A1	A0	Volume 1.25dB steps
					0	0	0	0
					0	0	1	-1.25
					0	1	0	-2.5
					0	1	1	-3.75
					1	0	0	-5
					1	0	1	-6.25
					1	1	0	-7.5
					1	1	1	-8.75
0	0	B2	B1	B0	A2	A1	A0	Volume 10dB steps
		0	0	0				0
		0	0	1				-10
		0	1	0				-20
		0	1	1				-30
		1	0	0				-40
		1	0	1				-50
		1	1	0				-60
		1	1	1				-70

For example a volume of -45dB is given by:

0 0 1 0 0 1 0 0

Table 8. Speaker attenuators

MSB					LSB			FUNCTION
1	0	0	B1	B0	A2	A1	A0	Speaker LF
1	0	1	B1	B0	A2	A1	A0	Speaker RF
1	1	0	B1	B0	A2	A1	A0	Speaker LR
1	1	1	B1	B0	A2	A1	A0	Speaker RR
					0	0	0	0
					0	0	1	-1.25
					0	1	0	-2.5
					0	1	1	-3.75
					1	0	0	-5
					1	0	1	-6.25
					1	1	0	-7.5
					1	1	1	-8.75
			0	0				0
			0	1				-10
			1	0				-20
			1	1				-30
			1	1	1	1	1	Mute

For example attenuation of 25dB on speaker RF is given by: 1 0 1 1 0 1 0 0

Table 9. Audio switch

MSB				LSB				FUNCTION
0	1	0	G1	G0	S2	S1	S0	
						0	0	Audio Switch
						0	1	Stereo 1
						1	0	Stereo 2
						1	1	Stereo 3
					0			Not allowed
					1			Loudness ON
					0			Loudness OFF
		0	0					+11.25dB
		0	1					+7.5dB
		1	0					+3.75dB
		1	1					0dB

For example to select the stereo 2 input with a gain of +7.5dB LOUDNESS ON the 8bit string is: 0 1 0 0 1 0 0 1

Table 10. Bass and Treble

MSB				LSB				FUNCTION
0	1	1	0	C3	C2	C1	C0	
								Bass
								Treble
				0	0	0	0	-14
				0	0	0	1	-12
				0	0	1	0	-10
				0	0	1	1	-8
				0	1	0	0	-6
				0	1	0	1	-4
				0	1	1	0	-2
				0	1	1	1	0
				1	1	1	1	0
				1	1	1	0	2
				1	1	0	1	4
				1	1	0	0	6
				1	0	1	1	8
				1	0	1	0	10
				1	0	0	1	12
				1	0	0	0	14

C3 = Sign

For example Bass at -10dB is obtained by the following 8 bit string: 0 1 1 0 0 0 1 0

5 Package information

In order to meet environmental requirements, ST offers these devices in ECOPACK® packages. These packages have a Lead-free second level interconnect. The category of second Level Interconnect is marked on the package and on the inner box label, in compliance with JEDEC Standard JESD97. The maximum ratings related to soldering conditions are also marked on the inner box label. ECOPACK is an ST trademark. ECOPACK specifications are available at: www.st.com.

Figure 23. SO-28 Mechanical Data & Package Dimensions

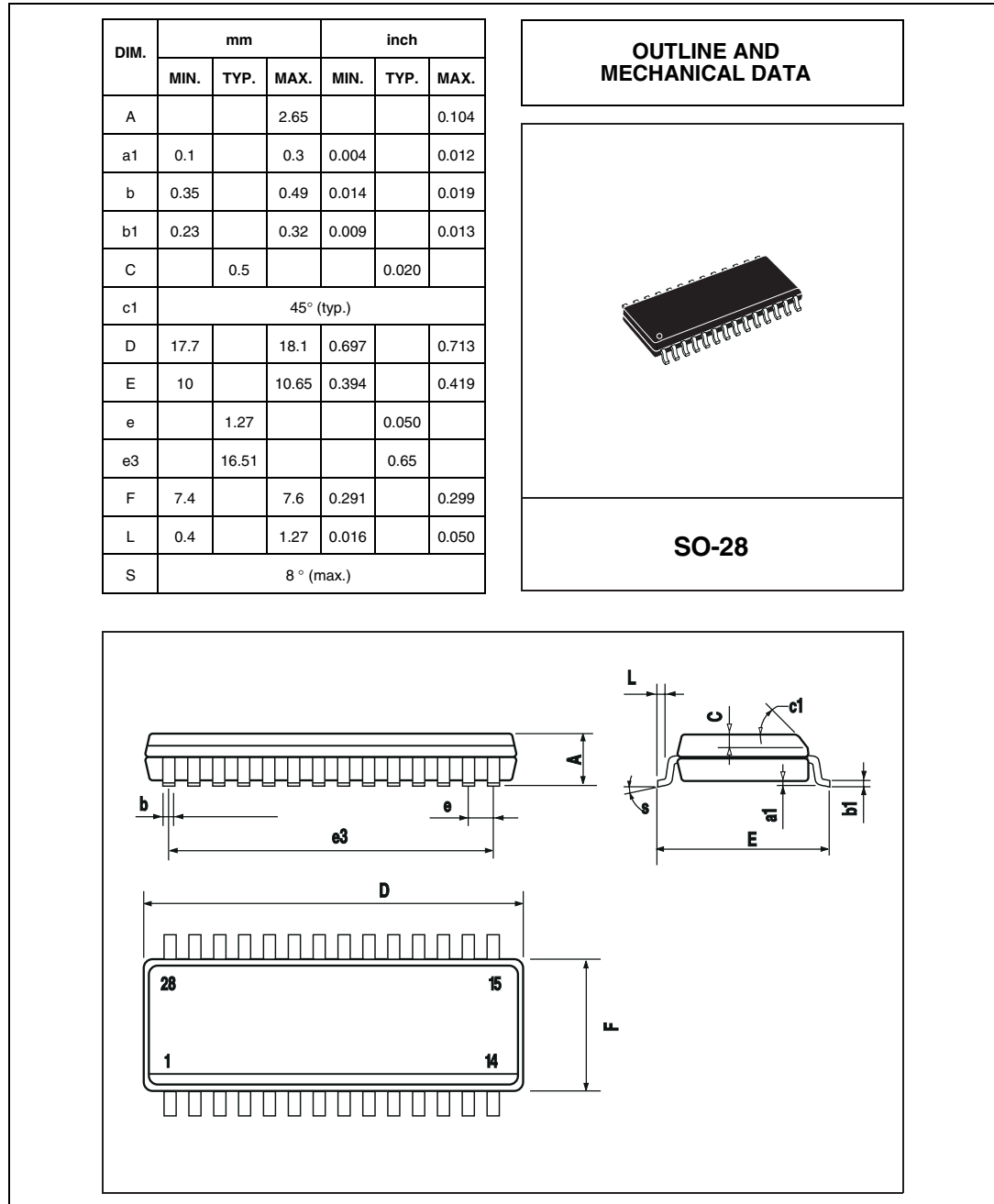

6 Revision history

Table 11. Document revision history

Date	Revision	Changes
04-Aug-2006	1	Initial release.

Please Read Carefully:

Information in this document is provided solely in connection with ST products. STMicroelectronics NV and its subsidiaries ("ST") reserve the right to make changes, corrections, modifications or improvements, to this document, and the products and services described herein at any time, without notice.

All ST products are sold pursuant to ST's terms and conditions of sale.

Purchasers are solely responsible for the choice, selection and use of the ST products and services described herein, and ST assumes no liability whatsoever relating to the choice, selection or use of the ST products and services described herein.

No license, express or implied, by estoppel or otherwise, to any intellectual property rights is granted under this document. If any part of this document refers to any third party products or services it shall not be deemed a license grant by ST for the use of such third party products or services, or any intellectual property contained therein or considered as a warranty covering the use in any manner whatsoever of such third party products or services or any intellectual property contained therein.

UNLESS OTHERWISE SET FORTH IN ST'S TERMS AND CONDITIONS OF SALE ST DISCLAIMS ANY EXPRESS OR IMPLIED WARRANTY WITH RESPECT TO THE USE AND/OR SALE OF ST PRODUCTS INCLUDING WITHOUT LIMITATION IMPLIED WARRANTIES OF MERCHANTABILITY, FITNESS FOR A PARTICULAR PURPOSE (AND THEIR EQUIVALENTS UNDER THE LAWS OF ANY JURISDICTION), OR INFRINGEMENT OF ANY PATENT, COPYRIGHT OR OTHER INTELLECTUAL PROPERTY RIGHT.

UNLESS EXPRESSLY APPROVED IN WRITING BY AN AUTHORIZED ST REPRESENTATIVE, ST PRODUCTS ARE NOT RECOMMENDED, AUTHORIZED OR WARRANTED FOR USE IN MILITARY, AIR CRAFT, SPACE, LIFE SAVING, OR LIFE SUSTAINING APPLICATIONS, NOR IN PRODUCTS OR SYSTEMS WHERE FAILURE OR MALFUNCTION MAY RESULT IN PERSONAL INJURY, DEATH, OR SEVERE PROPERTY OR ENVIRONMENTAL DAMAGE. ST PRODUCTS WHICH ARE NOT SPECIFIED AS "AUTOMOTIVE GRADE" MAY ONLY BE USED IN AUTOMOTIVE APPLICATIONS AT USER'S OWN RISK.

Resale of ST products with provisions different from the statements and/or technical features set forth in this document shall immediately void any warranty granted by ST for the ST product or service described herein and shall not create or extend in any manner whatsoever, any liability of ST.

ST and the ST logo are trademarks or registered trademarks of ST in various countries.

Information in this document supersedes and replaces all information previously supplied.

The ST logo is a registered trademark of STMicroelectronics. All other names are the property of their respective owners.

© 2006 STMicroelectronics - All rights reserved

STMicroelectronics group of companies

Australia - Belgium - Brazil - Canada - China - Czech Republic - Finland - France - Germany - Hong Kong - India - Israel - Italy - Japan - Malaysia - Malta - Morocco - Singapore - Spain - Sweden - Switzerland - United Kingdom - United States of America

www.st.com

Find price and stock options from leading distributors for TDA7303 on Findchips.com:

<https://findchips.com/search/TDA7303>

Find CAD models and details for this part:

<https://findchips.com/detail/tda7303/STMicroelectronics>