

Data Sheet

Features

- Triple Voltage Regulator
- Output Voltage 5 V with 450 mA Current Capability
- Two tracked Outputs for 50 mA and 100 mA
- Enable Function for main and tracked Output(s)
- Reset with adjustable Threshold
- Undervoltage- and Power On-Reset
- Watchdog
- Independent Watchdog- and Resetdelay
- Wide Temperature Range
- Overtemperature Protection
- Overvoltage Protection
- Reverse Polarity Proof

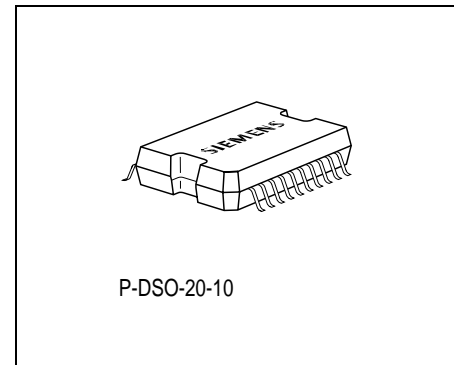

Type	Ordering Code	Package
A2C33648 ▼	Q67007-A9438	P-DSO-20-12 (SMD)

New type ▼

Fun Aescription

The A2C33648 is a monolithic integrated very low-drop triple voltage regulator. The deimain output supplies loads up to 450 mA and the additional tracked outputs can prov up to 50 mA and 100 mA. In addition the device includes a watchdog for microcontroller-supervision, an under-voltage reset, a power on reset and extended enabling features. The watchdog and reset timing can be chosen independently of each other. The A2C33648 is available in the P-DSO-20-12 power package. It is designed to supply microprocessor systems under the severe condition of automotive applications and therefore it is equipped with additional protection against overload, short circuit and . overtemperature. Of course the A2C33648 can be used in other applications as well .The A2C33648 operates in the temperature range of $T_j = -40$ to 150 °C

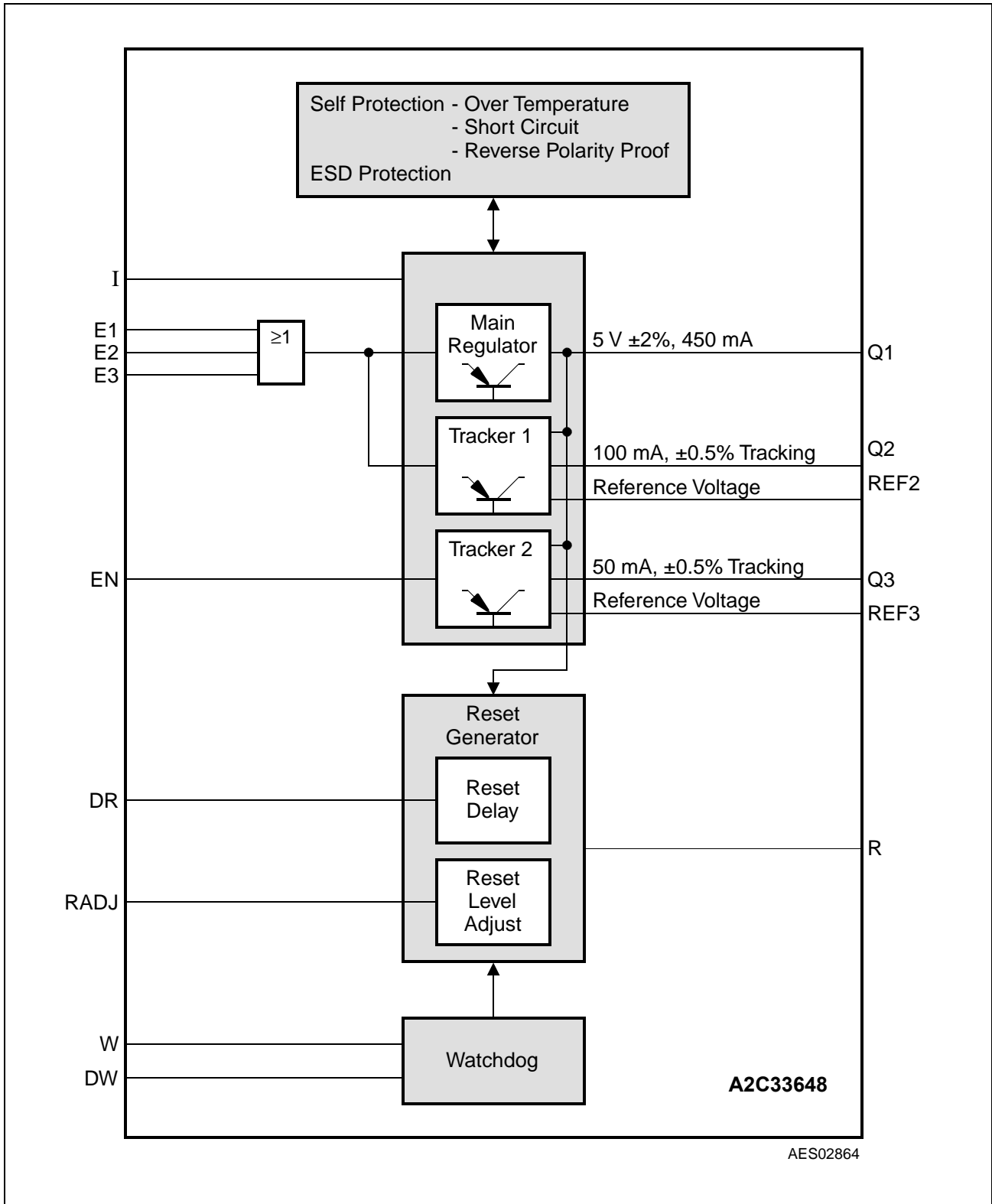

Figure 1 Block Diagram

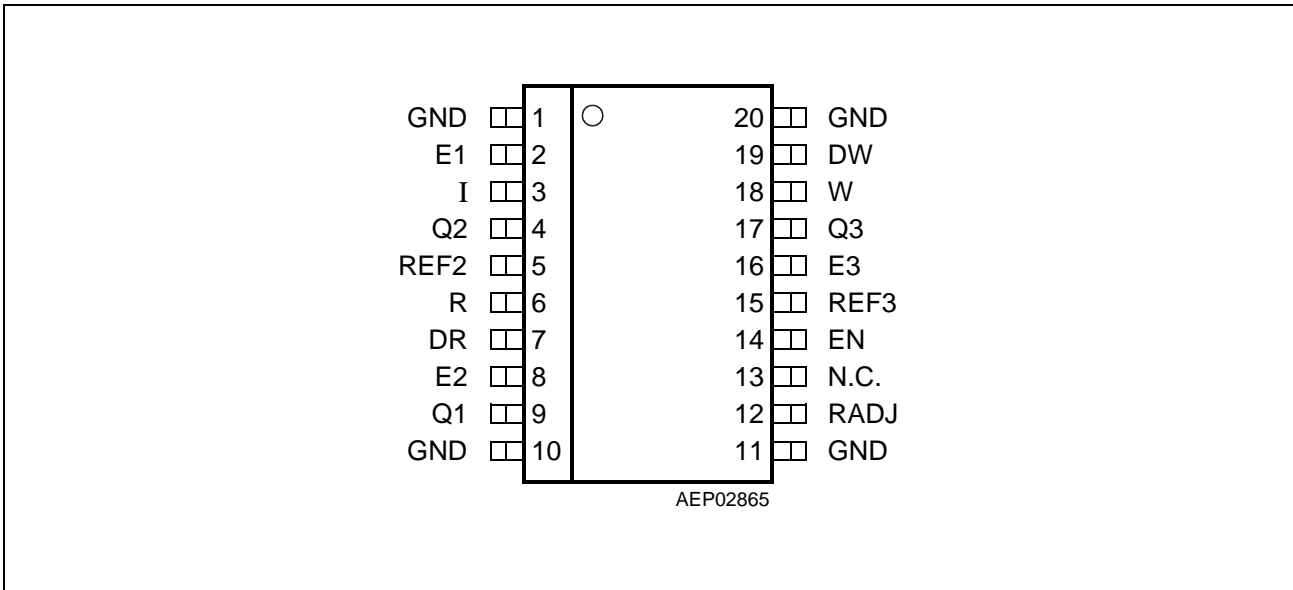

Figure 2 Pin Configuration (top view)

Pin Definitions and Functions

Pin No.	Symbol	Function
1, 10, 11, 20	GND	GROUND
2	E1	Enable 1: Enable for Main Output Q1 and Q2; E1, E2 and E3 are ored together; connect to GND, if not needed.
3	I	Input; block to ground directly at the IC for line compensation.
4	Q2	Tracking Output Q2; block to GND with min. 10 μ F with ESR < 3 Ω .
5	REF2	Reference Output; Reference Voltage related to Q2.
6	R	Reset Output; the open collector Output is connected to Q1 via an integrated resistor.
7	DR	Reset Delay; connect a capacitor to GND for reset delay time adjustment.
8	E2	Enable 2: Enable for Main Output Q1 and Q2; E1, E2 and E3 are ored together; connect to GND, if not needed.
9	Q1	Main Output Q1; block to GND with min. 22 μ F, ESR < 3 Ω .
12	RADJ	Reset Switching Threshold Adjust; The reset threshold can be set individually with an external voltage divider at the pin. If it is connected straight to GND the reset threshold remains at 4.65 V.
13	NC	Not Connected

Pin Definitions and Functions (cont'd)

Pin No.	Symbol	Function
14	EN	Enable Input; enables Q3
15	REF3	Reference Output; Reference Voltage related to Q3.
16	E3	Enable 3: Enable for Main Output Q1 and Q2; E1, E2 and E3 are ored together; connect to GND, if not needed.
17	Q3	Tracker Output Q3; block to GND with min. 10 μ F with ESR < 3 Ω .
18	W	Watchdog Trigger Input; positive edge triggered input for monitoring a microcontroller.
19	DW	Watchdog Delay; connect a capacitor to GND for watchdog trigger time adjustment.

Absolute Maximum Ratings
 $T_j = -40 \text{ to } 150 \text{ } ^\circ\text{C}$

Parameter	Symbol	Limit Values		Unit	Notes
		min.	max.		

Input I

Input voltage	V_I	- 45	42	V	-
		-	60	V	$t < 400 \text{ ms}$

Main Output Q1

Output voltage	V_{Q1}	- 0.3	7	V	-
Output current	I_{Q1}	-	-	mA	internally limited

Tracking Output Q2

Output voltage	V_{Q2}	- 2	27	V	-
Output current	I_{Q2}	-	-	mA	internally limited

Tracking Output Q3

Output voltage	V_{Q3}	- 2	27	V	-
Output current	I_{Q3}	- 5	-	mA	internally limited

Enable Input E1

Input voltage	V_{E1}	- 0.3	16	V	-
Input current	I_{E1}	- 20	20	mA	-

Enable Input E2

Input voltage	V_{E2}	- 0.3	6.5	V	-
Input current	I_{E2}	-	-	mA	internally limited

Enable Input E3

Input voltage	V_{E3}	- 0.3	16	V	-
Input current	I_{E3}	- 20	20	mA	-

Absolute Maximum Ratings (cont'd)
 $T_j = -40$ to 150 °C

Parameter	Symbol	Limit Values		Unit	Notes
		min.	max.		

Enable Input EN

Input voltage	V_{EN}	- 0.3	7	V	-
Input current	I_{EN}	-	-	mA	internally limited

Reference Output REF2

Output voltage	V_{REF2}	- 0.3	4.5	V	-
Output current	I_{REF2}	-	-	mA	-

Reference Output REF3

Output voltage	V_{REF3}	- 0.3	4.5	V	-
Output current	I_{REF3}	-	-	mA	-

Reset Adjust Input RADJ

Input Voltage	V_{RADJ}	- 0.3	7	V	-
Input Current	I_{RADJ}	-	-	mA	internally limited

Reset Delay DR

Voltage	V_{DR}	- 0.3	7	V	-
---------	----------	-------	---	---	---

Reset Output R

Voltage	V_R	- 0.3	7	V	-
---------	-------	-------	---	---	---

Absolute Maximum Ratings (cont'd)

$T_j = -40$ to 150 °C

Parameter	Symbol	Limit Values		Unit	Notes
		min.	max.		

Watchdog Delay DW

Voltage	V_{DW}	- 0.3	7	V	-
---------	----------	-------	---	---	---

Watchdog Input W

Input voltage	V_W	- 0.3	7	V	-
Input current	I_W	-	-	mA	-

Temperature

Junction temperature	T_j	- 50	150	°C	-
Storage temperature	T_{Stg}	- 65	150	°C	-

Thermal Data

Junction-ambient	R_{thja}	-	-	K/W	-
	R_{thjp}	-	4	K/W	-

ESD

Human Body Model	-	- 2	2	kV	-
------------------	---	-----	---	----	---

Note: Stresses above those listed here may cause permanent damage to the device. Exposure to absolute maximum rating conditions for extended periods may affect device reliability.

Operating Range

Parameter	Symbol	Limit Values		Unit	Notes
		min.	max.		
Input voltage	V_I	5.5	40	V	–
Junction temperature	T_j	– 40	150	°C	–
Shutdown voltage threshold	V_{shut}	–	44	V	–

Note: In the operating range, the functions given in the circuit description are fulfilled.

Characteristics
 $V_I = 13.5 \text{ V}; T_j = -40 \text{ }^\circ\text{C} < T_j < 125 \text{ }^\circ\text{C}$

Parameter	Symbol	Limit Values			Unit	Measuring Condition
		min.	typ.	max.		

Main Output Q1

Output voltage	V_{Q1}	4.9	5.0	5.1	V	$10 \text{ mA} < I_{Q1} < 450 \text{ mA}$, $5.5 \text{ V} < V_I < 19 \text{ V}$
Output voltage	V_{Q1}	4.8	5.0	5.2	V	$10 \text{ mA} < I_{Q1} < 300 \text{ mA}$; $5.5 \text{ V} < V_I < 28 \text{ V}$
Output voltage	V_{Q1}	4.8	5.0	5.2	V	$10 \text{ mA} < I_{Q1} < 200 \text{ mA}$; $5.5 \text{ V} < V_I < 40 \text{ V}$
Output current limit	I_{Q1}	550	–	1500	mA	$V_{Q1} = 0.1 \text{ V}$
Output voltage drop	V_{DR}	–	0.25	0.55	V	$I_{Q1} = 450 \text{ mA}^{1)}$
Line regulation	ΔV_{Q1}	– 25	–	25	mV	$8 \text{ V} \leq V_I \leq 16 \text{ V}$; $I_{Q1} = 10 \text{ mA}$
Load regulation	ΔV_{Q1}	– 25	–	25	mV	$10 \text{ mA} < I_{Q1} < 450 \text{ mA}$; $V_I = 7 \text{ V}$
Power Supply Ripple Rejection	$PSRR$	30	–	–	dB	$C_{Q1} = 22 \text{ } \mu\text{F}$; $20 \text{ Hz} < f_r < 20 \text{ kHz}$; $V_{SS} = 0.5 \text{ V}$
Output capacitor	C_{Q1}	22	–	–	μF	–
ESR of output capacitor	ESR	–	–	3	Ω	at 10 kHz

¹⁾ Measured when the output voltage V_Q dropped 100 mV from the nominal value.

Characteristics (cont'd)
 $V_i = 13.5 \text{ V}; T_j = -40 \text{ }^\circ\text{C} < T_j < 125 \text{ }^\circ\text{C}$

Parameter	Symbol	Limit Values			Unit	Measuring Condition
		min.	typ.	max.		

Tracked Output Q2

Output voltage tracking accuracy	$\Delta V_{Q2} = V_{Q2} - V_{Q1}$	- 25	-	25	mV	$5.7 \text{ V} < V_i < 19 \text{ V};$ $1 \text{ mA} < I_{Q2} < 100 \text{ mA}$
Output voltage tracking accuracy	$\Delta V_{Q2} = V_{Q2} - V_{Q1}$	- 25	-	25	mV	$5.7 \text{ V} < V_i < 28 \text{ V};$ $1 \text{ mA} < I_{Q2} < 80 \text{ mA}$
Output voltage tracking accuracy	$\Delta V_{Q2} = V_{Q2} - V_{Q1}$	- 25	-	25	mV	$5.7 \text{ V} < V_i < 40 \text{ V};$ $1 \text{ mA} < I_{Q2} < 50 \text{ mA}$
Output current limit	I_{Q2}	110	-	-	mA	$V_{Q2} = 0.1 \text{ V}$
Output voltage drop	V_{DR2}	-	-	0.6	V	$I_{Q2} = 100 \text{ mA}$
Power Supply Ripple Rejection	<i>PSRR</i>	30	-	-	dB	$20 \text{ Hz} < f_r < 20 \text{ kHz};$ $V_{PP} = 0.5 \text{ V}; C_{Q2} = 10 \text{ } \mu\text{F}$
Output capacitor	C_{Q2}	10	-	-	μF	-
ESR of output capacitor	<i>ESR</i>	-	-	3	Ω	at 10 kHz

Tracked Output Q3

Output voltage tracking accuracy	$\Delta V_{Q3} = V_{Q3} - V_{Q1}$	- 25	-	25	mV	$5.7 \text{ V} < V_i < 19 \text{ V};$ $1 \text{ mA} < I_{Q3} < 50 \text{ mA}$
Output voltage tracking accuracy	$\Delta V_{Q3} = V_{Q3} - V_{Q1}$	- 25	-	25	mV	$5.7 \text{ V} < V_i < 28 \text{ V};$ $1 \text{ mA} < I_{Q3} < 40 \text{ mA}$
Output voltage tracking accuracy	$\Delta V_{Q3} = V_{Q3} - V_{Q1}$	- 25	-	25	mV	$5.7 \text{ V} < V_i < 40 \text{ V};$ $1 \text{ mA} < I_{Q3} < 25 \text{ mA}$
Output current limit	I_{Q3}	55	-	150	mA	$V_{Q3} = 0.1 \text{ V}$
Output voltage drop	V_{DR3}	-	-	0.6	V	$1 \text{ mA} \leq I_{Q3} \leq 50 \text{ mA}$
Power Supply Ripple Rejection	<i>PSRR</i>	30	-	-	dB	$20 \text{ Hz} < f_r < 20 \text{ kHz};$ $V_{PP} = 0.5 \text{ V}; C_{Q3} = 10 \text{ } \mu\text{F}$
Output capacitor	C_{Q3}	10	-	-	μF	-
ESR of output capacitor	<i>ESR</i>	-	-	3	Ω	at 10 kHz

Characteristics (cont'd)

$V_I = 13.5\text{ V}; T_j = -40\text{ }^\circ\text{C} < T_j < 125\text{ }^\circ\text{C}$

Parameter	Symbol	Limit Values			Unit	Measuring Condition
		min.	typ.	max.		
Matching error between V_{Q2} and V_{Q3}	$\Delta V_{Q2,3} = V_{Q3} - V_{Q2}$	- 25	-	25	mV	-

Current Consumption

Quiescent current (standby)	I_q	-	-	20	μA	Q1 OFF, Q2 OFF; Q3 OFF;
Current consumption; $I_q = I_I - I_Q$	I_q	-	1100	-	μA	Q3 OFF, $I_{Q1} < 1\text{ mA};$ $I_{Q2} < 1\text{ mA};$
Current consumption; $I_q = I_I - I_Q$	I_q	-	1800	-	μA	$I_{Q1} < 10\text{ mA};$ $I_{Q2} < 1\text{ mA};$ $I_{Q3} < 1\text{ mA};$

Characteristics (cont'd)
 $V_i = 13.5 \text{ V}; T_j = -40 \text{ }^\circ\text{C} < T_j < 125 \text{ }^\circ\text{C}$

Parameter	Symbol	Limit Values			Unit	Measuring Condition
		min.	typ.	max.		

Enable Function E1, E2, E3, EN

E1 On threshold	$V_{E1, on}$	3.5	4.1	4.5	V	$V_{Q1} > 4.8 \text{ V}; V_{Q2} > 4.8 \text{ V}$
E1 Off threshold	$V_{E1, off}$	1.5	–	2.5	V	–
E1 High input current	$I_{E1, on}$	–	50	–	μA	$V_{E1} = 16 \text{ V}$
E1 Low input current	$I_{E1, off}$	– 1	–	5	μA	$V_{E1} = 0 \text{ V}$
E2 On threshold	$V_{E2, on}$	1.3	1.7	2.0	V	$V_{Q1} > 4.8 \text{ V}; V_{Q2} > 4.8 \text{ V}$
E2 Off threshold	$V_{E2, off}$	0.8	1.2	1.7	V	–
E2 resistance to GND	R_{E2}	5	15	40	$\text{k}\Omega$	–
E3 On threshold	$V_{E3, on}$	3.5	–	4.5	V	$V_{Q1} > 4.8 \text{ V}; V_{Q2} > 4.8 \text{ V}$
E3 Off threshold	$V_{E3, off}$	1.5	–	2.5	V	–
E3 High input current	$I_{E3, on}$	–	50	–	μA	$V_{E3} = 16 \text{ V}$
E3 Low input current	$I_{E3, off}$	– 1	–	5	μA	$V_{E3} = 0 \text{ V}$
EN On threshold	$V_{EN, on}$	1.0	1.7	2.3	V	$V_{Q3} > 4.8 \text{ V}; Q1 \text{ ON}$
EN Off threshold	$V_{EN, off}$	0.8	1.2	1.7	V	$V_{Q3} < 0.1 \text{ V}$
Enable resistance to GND	R_{EN}	5	15	40	$\text{k}\Omega$	–

Characteristics (cont'd)
 $V_I = 13.5 \text{ V}; T_j = -40 \text{ }^\circ\text{C} < T_j < 125 \text{ }^\circ\text{C}$

Parameter	Symbol	Limit Values			Unit	Measuring Condition
		min.	typ.	max.		

Reset Generator

Switching threshold	$V_{Q, \text{rth}}$	4.5	4.65	4.8	V	RADJ connected to GND
Reset headroom	V_{head}	250	350	500	mV	$10 \text{ mA} < I_{Q1} < 450 \text{ mA}$
Reset pullup	R_R	2.4	–	6	k Ω	–
Reset output low voltage	$V_{R, \text{low}}$	–	–	0.4	V	$1 \text{ V} < V_{Q1} < V_{Q, \text{rth}}$
Reset output Low voltage	$V_{R, \text{low}}$	–	–	0.4	V	$V_{Q1} = 1 \text{ V}, I_R = 50 \text{ }\mu\text{A}$
Reset output High voltage	$V_{R, \text{high}}$	4.5	–	–	V	–
Reset adjust threshold	V_{RADJ}	1.25	1.35	1.45	V	$V_{Q1} > 3.5 \text{ V}$
Reset delay charging current	$I_{\text{DR, ch}}$	2	4	6	μA	$V_{\text{DR}} = 1 \text{ V}$
Reset delay discharge current	$I_{\text{DR, dis}}$	60	120	160	mA	$V_{\text{DR}} = 1 \text{ V}$
Upper reset timing threshold	$V_{\text{DR, dt}}$	0.9	1.8	2.7	V	–
Lower timing threshold	$V_{\text{DR, st}}$	0.25	0.4	0.65	V	–
Reset delay time	t_{dr}	35	50	70	ms	$C_R = 100 \text{ nF}$
Reset reaction time	t_{tr}	0.5	–	3	μs	$C_R = 100 \text{ nF}$

Characteristics (cont'd)

$V_I = 13.5\text{ V}; T_j = -40\text{ °C} < T_j < 125\text{ °C}$

Parameter	Symbol	Limit Values			Unit	Measuring Condition
		min.	typ.	max.		

Watchdog

Watchdog input pull down resistor	R_W	5	15	40	k Ω	–
Watchdog delay charging current	$I_{DW, ch}$	2	4	6	μA	$V_{DW} = 1\text{V}; V_{DR} = 2.7\text{V}$
Watchdog upper timing threshold	$V_{DW, dt}$	1.5	1.9	2.5	V	–
Watchdog lower timing threshold	$V_{DW, st}$	0	30	200	mV	–
Watchdog trigger pulse interval	t_{wp}	35	50	70	ms	$C_{DW} = 100\text{ nF};$

Characteristics (cont'd)

$V_i = 13.5 \text{ V}; T_j = -40 \text{ }^\circ\text{C} < T_j < 125 \text{ }^\circ\text{C}$

Parameter	Symbol	Limit Values			Unit	Measuring Condition
		min.	typ.	max.		

Reference Output REF2

Voltage divider ratio	V_{REF2}	49.5	50	50.5	% of V_{Q2}	–
Output impedance	R_{REF2}	10	–	20	k Ω	–
Output clamp voltage	–	–	–	4	V	–

Reference Output REF3

Voltage divider ratio	V_{REF3}	49.5	50	50.5	% of V_{Q3}	–
Output impedance	R_{REF3}	10	–	20	k Ω	–
Output clamp voltage	–	–	–	4	V	–

Note: The listed characteristics are ensured over the operating range of the integrated circuit. Typical characteristics specify mean values expected over the production spread. If not otherwise specified, typical characteristics apply at $T_A = 25 \text{ }^\circ\text{C}$ and the given supply voltage.

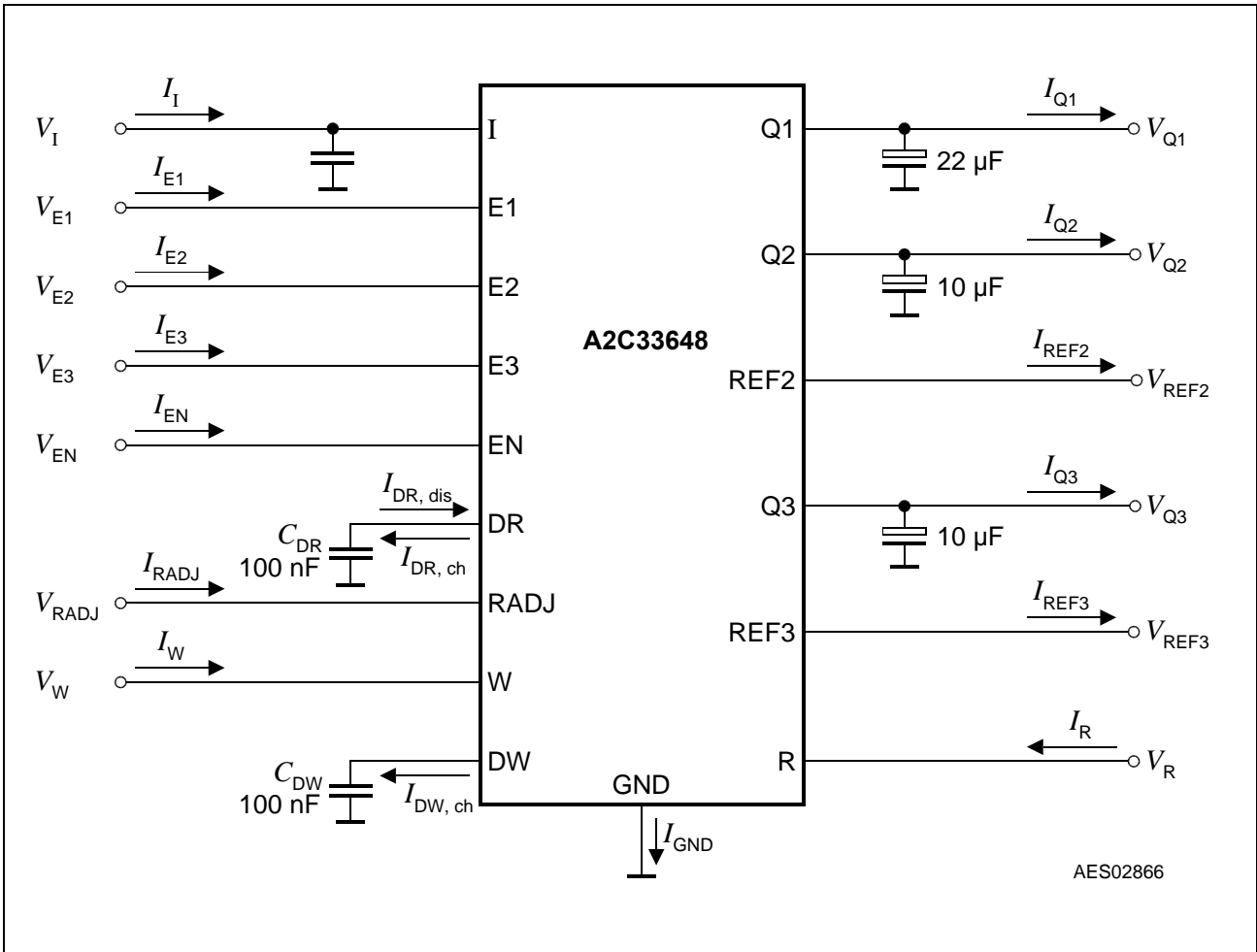

Figure 3 Measurement Circuit

Application Information

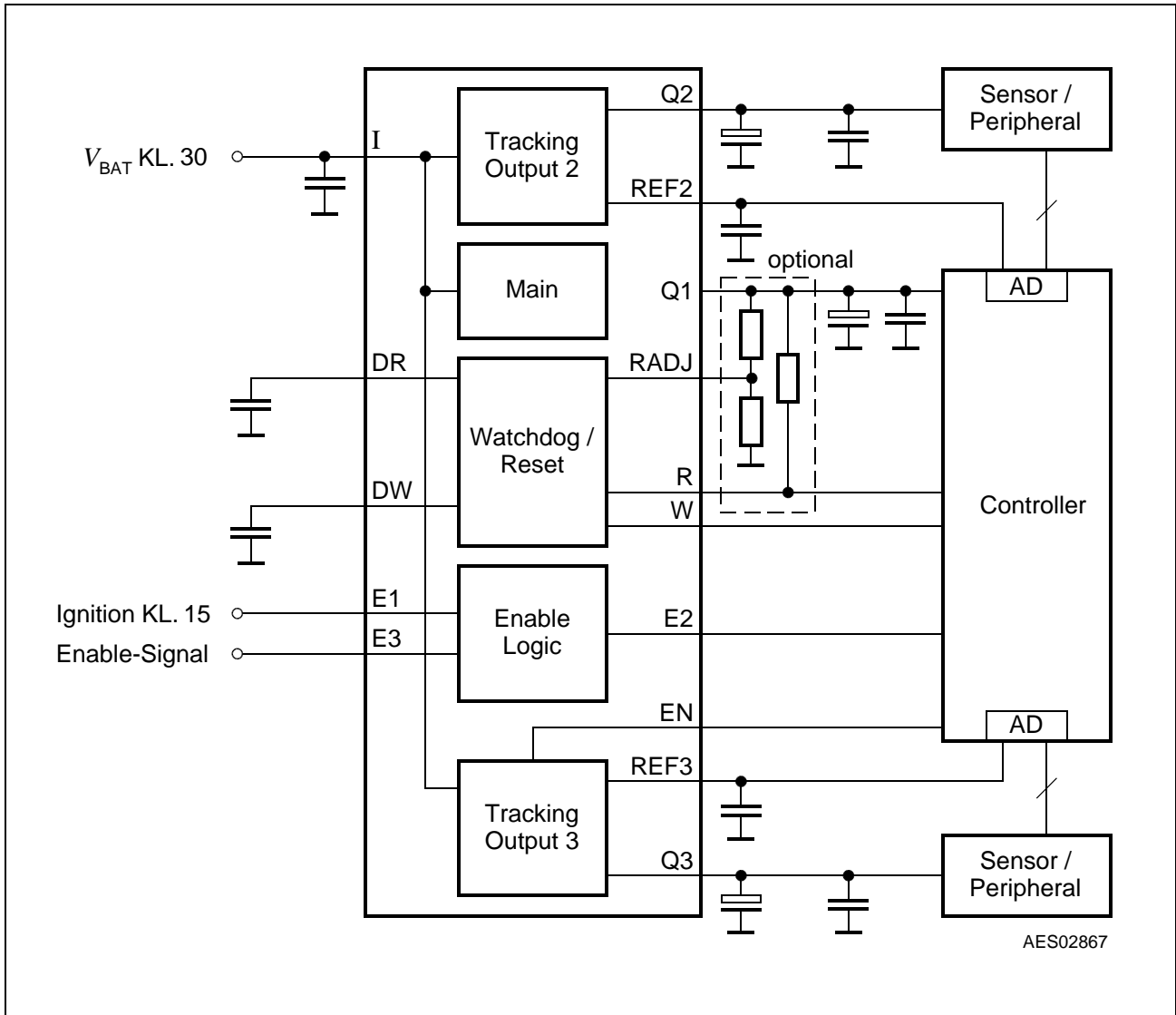

Figure 4 Application Diagram

Input

With an input voltage between $5.5\text{ V} < V_I < 40\text{ V}$ the regulator works in its normal operating range. If the input voltage exceeds the 40 V up to 60 V for less than 400 ms, e.g. caused by a load dump, the active components are switched off.

For compensating line influences and to avoid step input edges above $1\text{V}/\mu\text{s}$ an input capacitor is needed. Using a resistor of approx. 1Ω in series to the input capacitor, the oscillating circuit consisting of input inductance and input capacitor is damped.

Output Voltage

To obtain an output voltage of $V_{Q1} = 5\text{ V}$ with an accuracy of 2% at the main output Q1 an input voltage in the range of $5.5\text{ V} < V_1 < 40\text{ V}$ is needed. The main output Q1 supplies 5 V with 450 mA current capability. For stability it requires an output capacitor of at least 22 μF and a maximum ESR of 3 Ω . The two outputs Q2 and Q3 are tracked to Q1 and can supply currents of 100 mA and 50 mA. So any undervoltage condition or shutdown of Q1 will cause the same effect to Q2 and Q3. For Stability both outputs require an output capacitor of at least 10 μF with $\text{ESR} < 3\ \Omega$ each. Q2 is switched on and off simultaneously with Q1, while the tracked output Q3 can be enabled or disabled individually.

Two reference outputs REF2, REF3 with voltages of $V_{\text{REF2}} = V_{Q2}/2$ and $V_{\text{REF3}} = V_{Q3}/2$ are also available. In case of an overvoltage at the tracker outputs, the voltage references are limited internally to 4.5 V.

Output Current

The output current is a function of the input voltage. For high input voltages above 22 V, the output current is reduced linear. This is designed into the regulator for protection. Above 42 V the regulator is switched off. The thermal shutdown switches the regulator off, if it exceeds the thermal threshold of 160 °C typical. It is switched on again, as soon as the regulator is cooled down by typical 10 K (thermal hysteresis). Please note the device should not be operated above a junction temperature of 150 °C for long term reliability.

Enable Function

The A2C33648 includes the possibility of enabling the main and tracked outputs. Three ORed enable inputs E1, E2, E3 are used to control the main output Q1 and the tracked output Q2. E1 and E3 can be supplied from the battery line or ignition key with input voltages up to 16 V. The enable inputs should be protected by a series resistor and a capacitor, e.g. $R_{E1} = R_{E3} = 22\text{ k}\Omega$, $C_{E1} = C_{E3} = 2.2\text{ nF}$. E2 is intended for connection to the microcontroller. A logic HIGH at any enable input will switch on the related regulator and/or tracker.

A separate enabling pin EN is available to switch on and off the second tracked output Q3 separately by the microcontroller.

Reset

The power on reset feature is necessary for a defined start of the microprocessor during power up. When the output voltage of the main regulator has reached the reset threshold voltage the reset delay capacitor C_{DR} is charged. After a certain time, the reset delay time t_{dr} , the voltage at the capacitor equals the upper reset timing threshold and the reset output goes HIGH.

The reset delay time t_{dr} is defined by the reset delay capacitor C_{DR} at pin DR and can be calculated as follows:

$$t_{dr} = C_{DR} \cdot \frac{V_{DR,dt}}{I_{DR,ch}}$$

With C_{DR} reset delay capacitor
 t_{dr} reset delay time required by the application
 $V_{DR,dt}$ typical 1.8 V for power up reset
 $I_{DR,ch}$ charge current typical 4 μ A

For a delay capacitor $C_{DR} = 100$ nF the typical power up reset delay time is 45 ms.

The under-voltage reset circuitry supervises the output voltage. In case V_{Q1} falls below the reset threshold the reset output is set LOW after the reset reaction time t_{rr} (discharge of the reset delay capacitor). The reset LOW signal is held down to an output voltage V_{Q1} of 1 V. Both, the reset reaction time and the reset delay time are defined by the capacitor value.

The reset reaction time t_{rr} is the time it takes the voltage regulator to set its reset output LOW after the output voltage has dropped below the reset threshold. The reset reaction time can be calculated using the following equation:

$$t_{rr} = C_{DR} \cdot \frac{V_{DR,dt} - V_{DR,st}}{I_{DR,dis}}$$

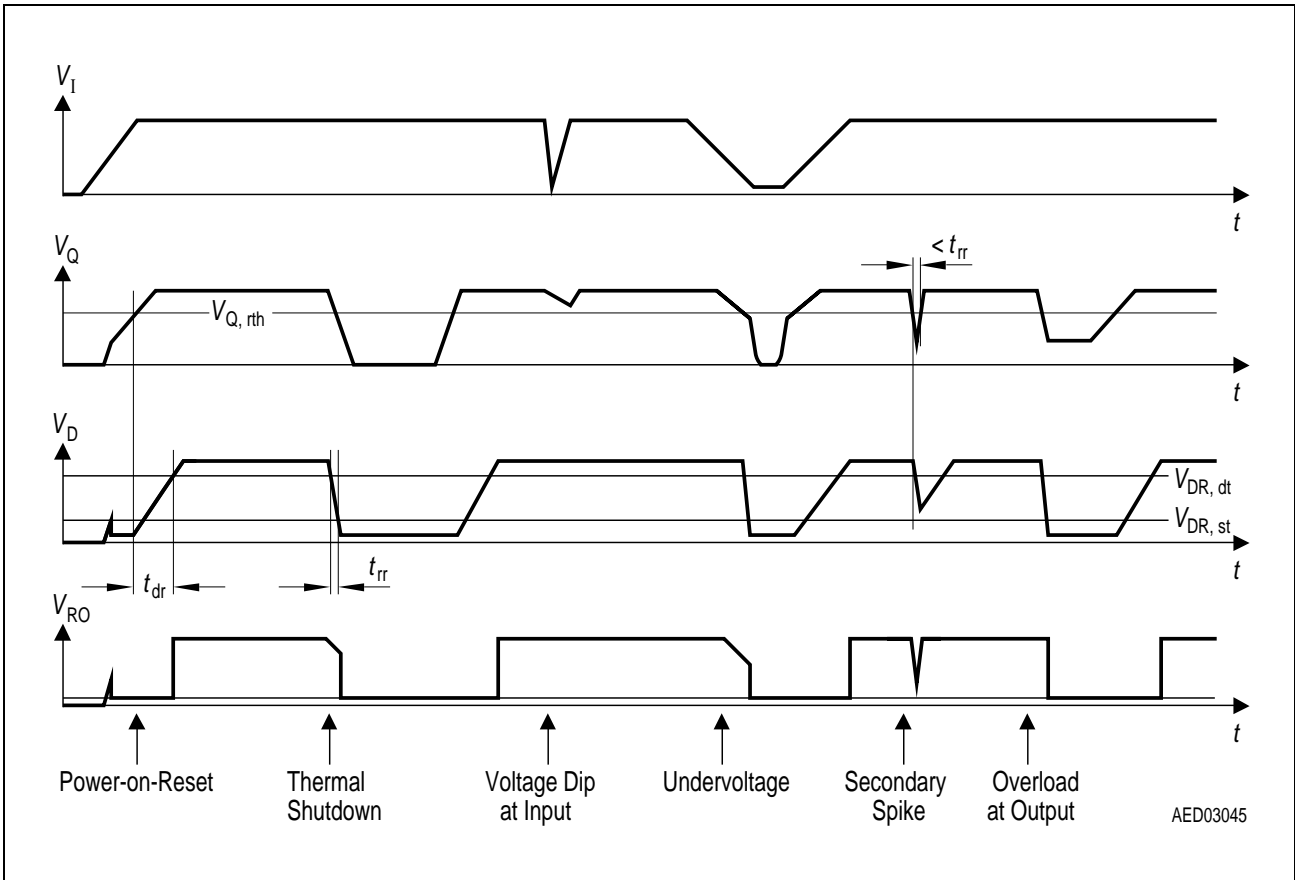

Figure 5 Reset Timing

The reset output is an open collector output with a pullup-resistor of typical 4 kΩ to Q1. An external pullup can be added with a resistor value of at least 20 kΩ.

In addition the reset switching threshold can be adjusted by an external voltage divider. The feature is useful with microprocessors which guarantee safe operation down to voltages below the internally set reset threshold of 4.65 typical.

Watchdog

The reset and watchdog timing can be defined independently of each other by two delay capacitors C_{DR} and C_{DW} at pins DR and DW.

The watchdog function supervises the microcontroller including time base failures. If there is no positive edge within a certain pulse repetition time t_{wp} or the triggerpulse is too short a reset is generated. Programming of the max. repetition time is done by a delay capacitor C_{DW} at pin DW.

The frequency of the watchdog pulses generated by the microcontroller has to be higher than the minimum pulse sequence t_{wp} set by the external reset delay capacitor C_{DW} . The pulse repetition time can be calculated as follows:

$$t_{wp} = C_{DW} \cdot \frac{V_{DW,dt} - V_{DW,st}}{I_{DW,ch}}$$

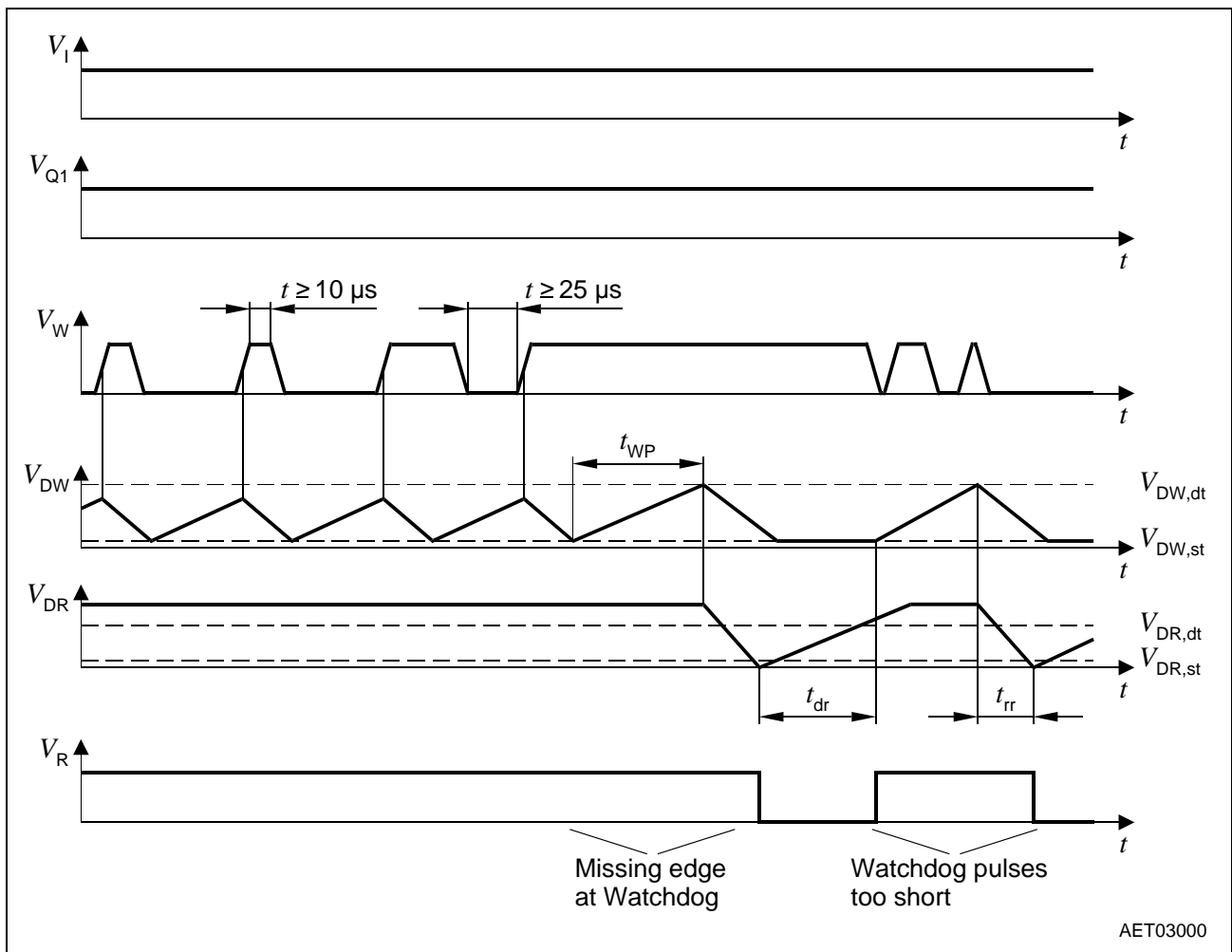
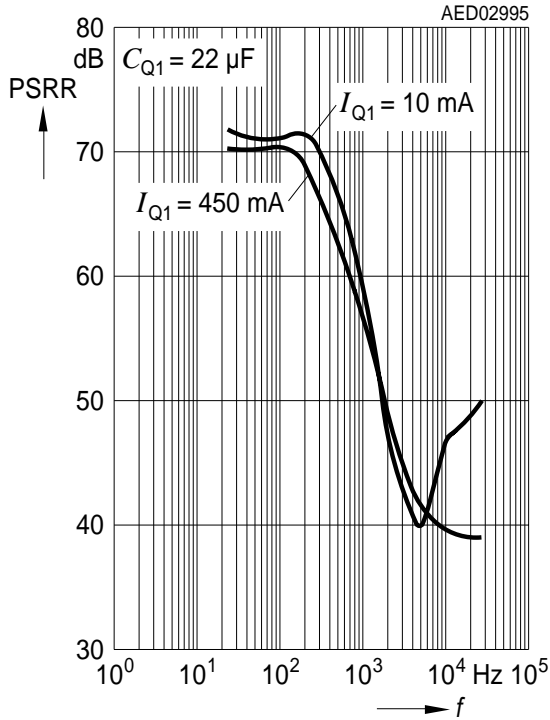

Figure 7 Watchdog Timing

If the watchdog is not used in an application the pin WD has to be connected to GND.

Power Supply Ripple Rejection PSRR of Main Output Q1 versus Frequency f



Power Supply Ripple Rejection PSRR of Output Q2 versus Frequency f

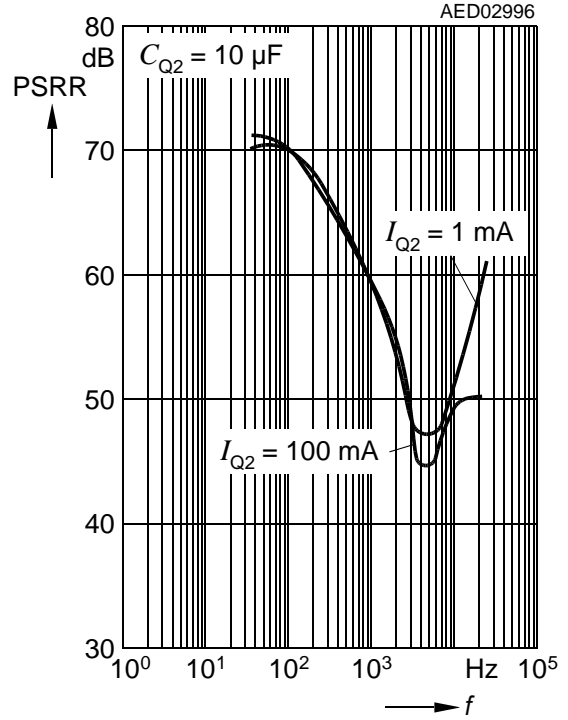

Power Supply Ripple Rejection PSRR of Output Q3 versus Frequency f

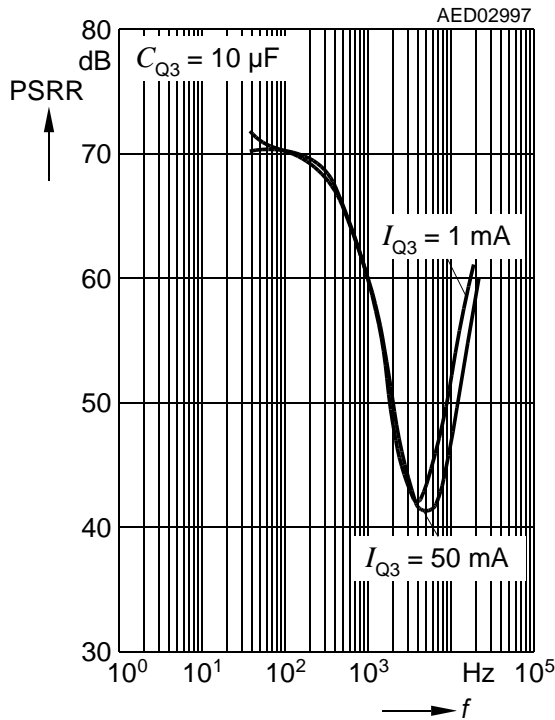

Enable Currents I_{E1} , I_{E3} and Output Voltage V_{Q1} versus Enable Voltages V_{E1} , V_{E3}

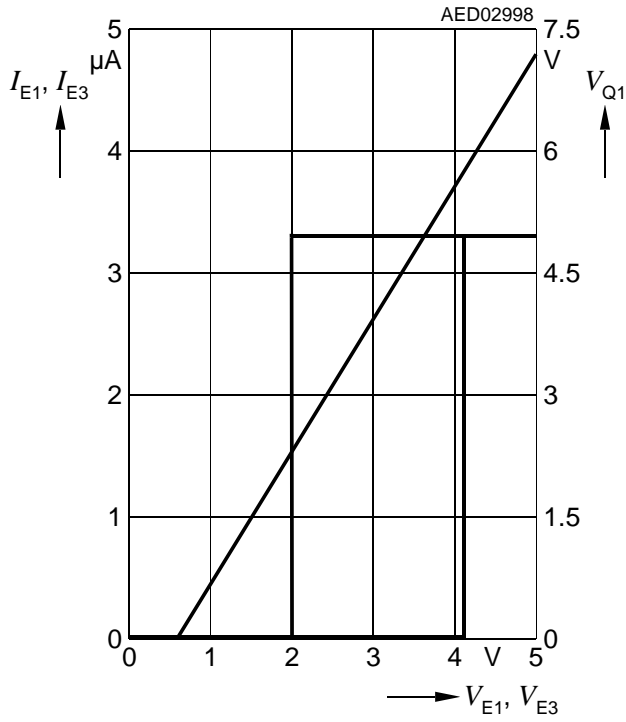

Enable Currents I_{E2} , I_{EN} and Output Voltage V_{Q3} versus Enable Voltages V_{E2} , V_{EN}

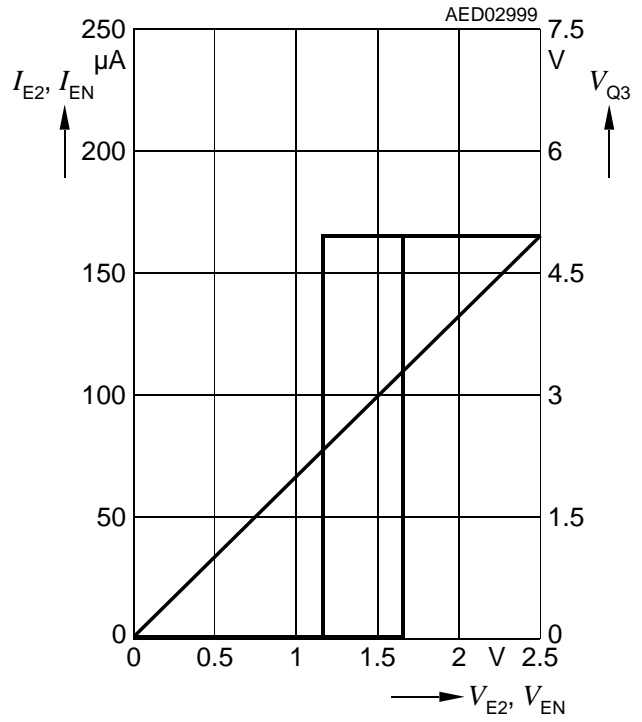

Package Outlines

P-DSO-20-12
(Plastic Dual Small Outline Package)

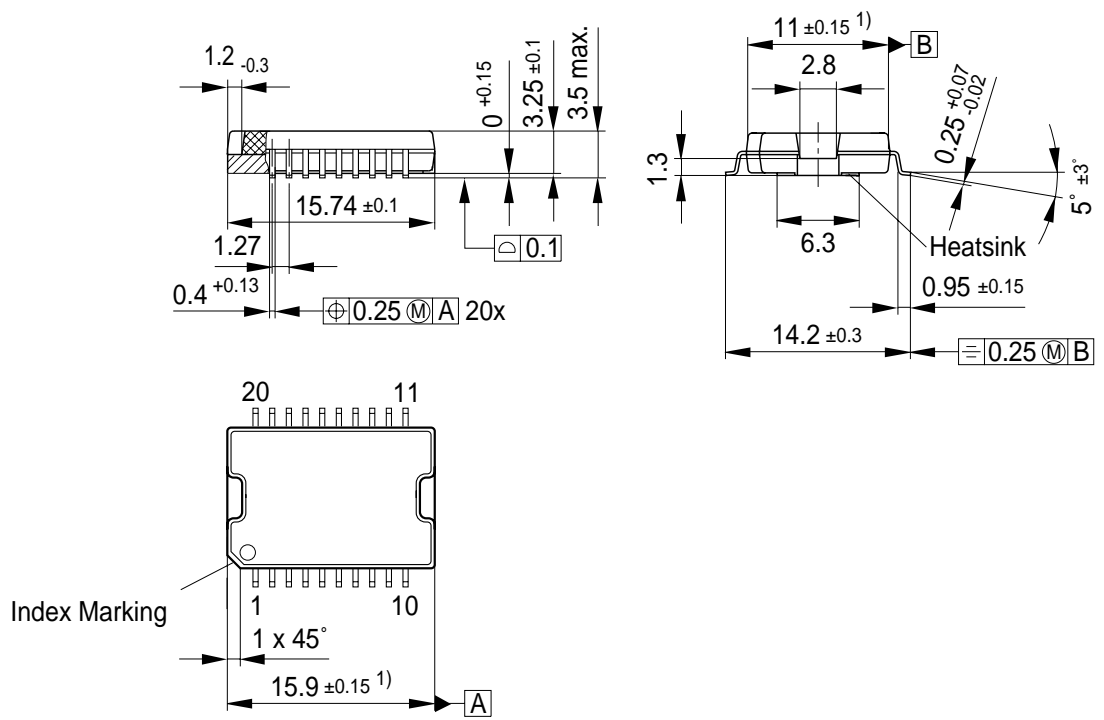

1) Does not include plastic or metal protrusion of 0.15 max. per side

GPS05791

Sorts of Packing

Package outlines for tubes, trays etc. are contained in our Data Book "Package Information"

SMD = Surface Mounted Device

Dimensions in mm

Edition 2001-09-06

**Published by Infineon Technologies AG,
St.-Martin-Strasse 53,
D-81541 München, Germany**

**© Infineon Technologies AG 2001.
All Rights Reserved.**

Attention please!

The information herein is given to describe certain components and shall not be considered as warranted characteristics.

Terms of delivery and rights to technical change reserved.

We hereby disclaim any and all warranties, including but not limited to warranties of non-infringement, regarding circuits, descriptions and charts stated herein.

Infineon Technologies is an approved CECC manufacturer.

Information

For further information on technology, delivery terms and conditions and prices please contact your nearest Infineon Technologies Office in Germany or our Infineon Technologies Representatives worldwide (see address list).

Warnings

Due to technical requirements components may contain dangerous substances. For information on the types in question please contact your nearest Infineon Technologies Office.

Infineon Technologies Components may only be used in life-support devices or systems with the express written approval of Infineon Technologies, if a failure of such components can reasonably be expected to cause the failure of that life-support device or system, or to affect the safety or effectiveness of that device or system. Life support devices or systems are intended to be implanted in the human body, or to support and/or maintain and sustain and/or protect human life. If they fail, it is reasonable to assume that the health of the user or other persons may be endangered.